

---

---

**UNITED STATES  
SECURITIES AND EXCHANGE COMMISSION**  
Washington, D.C. 20549

---

**FORM 20-F**

---

(Mark One)

- REGISTRATION STATEMENT PURSUANT TO SECTION 12(b) OR 12(g) OF THE SECURITIES EXCHANGE ACT OF 1934**

OR

- ANNUAL REPORT PURSUANT TO SECTION 13 OR 15(d) OF THE SECURITIES EXCHANGE ACT OF 1934**

For the fiscal year ended June 30, 2023

OR

- TRANSITION REPORT PURSUANT TO SECTION 13 OR 15(d) OF THE SECURITIES EXCHANGE ACT OF 1934**

For the transition period from \_\_\_\_\_ to \_\_\_\_\_

OR

- SHELL COMPANY REPORT PURSUANT TO SECTION 13 OR 15(d) OF THE SECURITIES EXCHANGE ACT OF 1934**

Date of event requiring this shell company report:

Commission File Number: 001-41789

---

**noco-noco Inc.**

(Exact name of Registrant as specified in its charter)

---

**Not applicable**  
(Translation of Registrant's  
name into English)

**Cayman Islands**  
(Jurisdiction of incorporation  
or organization)

4 Shenton Way  
#04-06 SGX Centre II  
Singapore 068807  
(Address of principal executive offices)

Masataka Matsumura  
Chief Executive Officer  
contactus@noco-noco.com  
4 Shenton Way  
#04-06 SGX Centre II  
Singapore 068807  
Telephone: +65 69709643

(Name, Telephone, Email and/or Facsimile number and Address of Company Contact Person)

---

[Table of Contents](#)

**Securities registered or to be registered pursuant to Section 12(b) of the Act:**

<u>Title of each class</u>	<u>Trading Symbol(s)</u>	<u>Name of exchange on which registered</u>
Ordinary shares, par value US\$0.0001	NCNC	The Nasdaq Capital Market LLC
Warrants, each whole warrant exercisable for one ordinary share	NCNCW	The Nasdaq Capital Market LLC

**Securities registered or to be registered pursuant to Section 12(g) of the Act:**

None  
(Title of Class)

**Securities for which there is a reporting obligation pursuant to Section 15(d) of the Act:**

None  
(Title of Class)

Indicate the number of outstanding shares of the issuer as of the close of the period covered by the annual report: 135,430,452 ordinary shares as of the date of this annual report.

Indicate by check mark if the registrant is a well-known seasoned issuer, as defined in Rule 405 of the Securities Act. Yes  No

If this report is an annual or transition report, indicate by check mark if the registrant is not required to file reports pursuant to Section 13 or 15(d) of the Securities Exchange Act of 1934. Yes  No

Indicate by check mark whether the registrant (1) has filed all reports required to be filed by Section 13 or 15(d) of the Securities Exchange Act of 1934 during the preceding 12 months (or for such shorter period that the registrant was required to file such reports), and (2) has been subject to such filing requirements for the past 90 days. Yes  No

Indicate by check mark whether the registrant has submitted electronically every Interactive Data File required to be submitted pursuant to Rule 405 of Regulation S-T (§232.405 of this chapter) during the preceding 12 months (or for such shorter period that the registrant was required to submit and post such files). Yes  No

Indicate by check mark whether the registrant is a large accelerated filer, an accelerated filer, a non-accelerated filer, or an emerging growth company. See definition of “large accelerated filer,” “accelerated filer,” and “emerging growth company” in Rule 12b-2 of the Exchange Act.

Large accelerated filer  Accelerated filer

Non-accelerated filer  Emerging growth company

If an emerging growth company that prepares its financial statements in accordance with U.S. GAAP, indicate by check mark if the registrant has elected not to use the extended transition period for complying with any new or revised financial accounting standards<sup>†</sup> provided pursuant to Section 13(a) of the Exchange Act.

Indicate by check mark whether the registrant has filed a report on and attestation to its management’s assessment of the effectiveness of its internal control over financial reporting over Section 404(b) of the Sarbanes-Oxley Act (15 U.S.C. 7262(b)) by the registered public accounting firm that prepared or issued its audit report. Yes  No

If securities are registered pursuant to Section 12(b) of the Act, indicate by check mark whether the financial statements of the registrant included in the filing reflect the correction of an error to previously issued financial statements.

Indicate by check mark whether any of those error corrections are restatements that required a recovery analysis of incentive-based compensation received by any of the registrant’s executive officers during the relevant recovery period pursuant to § 240.10D-1(b).

Indicate by check mark which basis of accounting the registrant has used to prepare the financial statements included in this filing:

U.S. GAAP  International Financial Reporting Standards as issued by the International Accounting Standards Board  Other

If “Other” has been checked in response to the previous question indicate by check mark which financial statement item the registrant has elected to follow. Item 17  Item 18

If this is an annual report, indicate by check mark whether the registrant is a shell company (as defined in Rule 12b-2 of the Exchange Act). Yes  No

† The term “new or revised financial accounting standard” refers to any update issued by the Financial Accounting Standards Board to its Accounting Standards Codification after April 5, 2012.

---

## Table of Contents

### TABLE OF CONTENTS

	<b>Pag e</b>
<u>EXPLANATORY NOTE</u>	1
<u>INTRODUCTION</u>	2
<u>CAUTIONARY NOTE REGARDING FORWARD-LOOKING STATEMENTS</u>	4
<u>PART I</u>	5
<u>ITEM 1. IDENTITY OF DIRECTORS, SENIOR MANAGEMENT AND ADVISERS</u>	5
<u>ITEM 2. OFFER STATISTICS AND EXPECTED TIMETABLE</u>	5
<u>ITEM 3. KEY INFORMATION</u>	5
<u>ITEM 4. INFORMATION ON THE COMPANY</u>	30
<u>ITEM 4A. UNRESOLVED STAFF COMMENTS</u>	45
<u>ITEM 5. OPERATING AND FINANCIAL REVIEW AND PROSPECTS</u>	45
<u>ITEM 6. DIRECTORS, SENIOR MANAGEMENT AND EMPLOYEES</u>	52
<u>ITEM 7. MAJOR SHAREHOLDERS AND RELATED PARTY TRANSACTIONS</u>	59
<u>ITEM 8. FINANCIAL INFORMATION</u>	62
<u>ITEM 9. THE OFFER AND LISTING</u>	62
<u>ITEM 10. ADDITIONAL INFORMATION</u>	63
<u>ITEM 11. QUANTITATIVE AND QUALITATIVE DISCLOSURES ABOUT MARKET RISK</u>	69
<u>ITEM 12. DESCRIPTION OF SECURITIES OTHER THAN EQUITY SECURITIES</u>	69
<u>PART II</u>	70
<u>ITEM 13. DEFAULTS, DIVIDED ARREARAGES AND DELINQUENCIES</u>	70
<u>ITEM 14. MATERIAL MODIFICATIONS TO THE RIGHTS OF SECURITY HOLDERS AND USE OF PROCEEDS</u>	70
<u>ITEM 15. CONTROLS AND PROCEDURES</u>	70
<u>ITEM 16. RESERVED</u>	71
<u>ITEM 16A. AUDIT COMMITTEE FINANCIAL EXPERT</u>	71
<u>ITEM 16B. CODE OF ETHICS</u>	71
<u>ITEM 16C. PRINCIPAL ACCOUNTANT FEES AND SERVICES</u>	71
<u>ITEM 16D. EXEMPTIONS FROM THE LISTING STANDARDS FOR AUDIT COMMITTEES</u>	71
<u>ITEM 16E. PURCHASES OF EQUITY SECURITIES BY THE ISSUER AND THE AFFILIATED PURCHASERS</u>	71
<u>ITEM 16F. CHANGE IN REGISTRANTS CERTIFYING ACCOUNTANT</u>	71
<u>ITEM 16G. CORPORATE GOVERNANCE</u>	72
<u>ITEM 16H. MINE SAFETY DISCLOSURE</u>	73
<u>ITEM 16I. DISLCOSURE REGARDING FOREIGN JURISDICTIONS THAT PREVENT INSEPCTIONS</u>	73
<u>ITEM 16J. INSIDER TRADING POLCIES</u>	73
<u>PART III</u>	74
<u>ITEM 17. FINANCIAL STATEMENTS</u>	74
<u>ITEM 18. FINANCIAL STATEMENTS</u>	74
<u>ITEM 19. EXHIBITS</u>	74
<u>EXHIBIT INDEX</u>	74
<u>SIGNATURE</u>	76

---

## EXPLANATORY NOTE

On August 25, 2023 (the “Closing Date”), noco-noco Inc. (formerly known as Prime Number Holding Limited), an exempted company with limited liability incorporated under the laws of the Cayman Islands (the “Company” or “PubCo”), consummated the previously announced Business Combination (defined below). The Business Combination was announced on December 29, 2022, where PubCo, Prime Number Acquisition I Corp. (“PNAC”), Prime Number Merger Sub Inc., a Delaware corporation and a direct wholly-owned subsidiary of PubCo (“Merger Sub”), Prime Number New Sub Pte. Ltd., a Singapore private company limited by shares and a direct wholly-owned subsidiary of PubCo (“New SubCo”), NOCO-NOCO PTE. LTD., a Singapore private company limited by shares (“noco-noco”), and certain shareholders of noco-noco collectively holding a controlling interest (together with other shareholders of noco-noco subsequently joining the transactions, the “Sellers”), entered into a business combination agreement (“Business Combination Agreement”), pursuant to which, PNAC proposed to enter into a business combination with noco-noco involving a merger and a share exchange, among which: (i) Merger Sub would merge with and into PNAC, with PNAC as the surviving entity and a wholly-owned subsidiary of PubCo (the “Merger”), (ii) New SubCo would acquire all of the issued and outstanding shares of noco-noco from the Sellers, and in exchange, PubCo would issue to the Sellers the ordinary shares of PubCo, with noco-noco becoming a subsidiary of New SubCo and an indirect subsidiary of PubCo (the “Share Exchange”, and together with the Merger and the other transactions contemplated by the Business Combination Agreement, the “Business Combination”). Upon the consummation of the Business Combination, each of PNAC and noco-noco would become a subsidiary of PubCo, and PNAC stockholders and the Sellers would receive ordinary shares, par value \$0.0001 per share, of PubCo (“PubCo Ordinary Shares”) as consideration and become the shareholders of PubCo. The Merger was consummated on August 24, 2023, and the Share Exchange and Business Combination were consummated on the Closing Date.

Pursuant to the Business Combination Agreement, upon the consummation of the Business Combination: (i) each PNAC unit (“PNAC Units”) issued and outstanding immediately prior to the effective time of the Merger was automatically detached and the holder thereof was deemed to hold one share of PNAC Class A Common Stock (defined below), one half of PNAC Warrant (defined below), and one PNAC Right (defined below); (ii) each share of PNAC Class A common stock, par value \$0.0001 per share (“PNAC Class A Common Stock”, together with PNAC Class B Common Stock, par value \$0.0001 per share, the “PNAC Common Stock”) issued and outstanding immediately prior to the effective time of the Merger was canceled in exchange for the right to receive one PubCo Ordinary Share, (iii) each PNAC warrant (“PNAC Warrant”) outstanding immediately prior to the effective time of the Merger ceased to be a warrant with respect to PNAC Common Stock and was assumed by PubCo and converted into a warrant of PubCo (“PubCo Warrant”) to purchase one PubCo Ordinary Share subject to substantially the same terms and conditions prior to the effective time of the Merger; and (iv) each PNAC Right (“PNAC Right”) outstanding immediately prior to the effective time of the Merger was cancelled in exchange for the right to receive one-eighth (1/8) of one PubCo Ordinary Share. In addition, pursuant to the Business Combination Agreement, upon the consummation of the Share Exchange (i) New SubCo acquired all the outstanding shares of noco-noco (“noco-noco Shares”) from the Sellers, (ii) in exchange, each Seller received such number of newly issued PubCo Ordinary Share that was equal to the product of (a) the quotient of (i) \$1,350,000,000 (the “noco- noco Valuation”), divided by (ii) the price per PubCo Ordinary Share that equals to the redemption price of each share of PNAC Class A Common Stock in connection with the Business Combination (the “PubCo Per Share Price”), multiplied by (b) such Seller’s Pro Rata Portion as set out in the Allocation Schedule of the Business Combination Agreement.

On August 28, 2023, the PubCo Ordinary Shares and PubCo Warrants commenced trading on the Nasdaq Capital Market (“Nasdaq”) under the symbols “NCNC” and “NCNCW”, respectively.

## INTRODUCTION

### Frequently Used Terms

In this annual report on Form 20-F (this “Report”), unless the context otherwise requires, the “Company,” “noco-noco” and references to “we,” “us,” or similar such references should be understood to be references to noco-noco Inc. and its subsidiaries. When this Report refers to “noco-noco” “we,” “us,” or similar such references in the context of discussing noco-noco Pte. Ltd.’s business or other affairs prior to the consummation of the Business Combination on August 25, 2023, it refers to the business of noco-noco Pte. Ltd. and its subsidiaries. Following the date of consummation of the Business Combination, references to “noco-noco” “we,” “us,” or similar such references should be understood to refer to noco-noco Inc. and its subsidiaries. References to “PNAC” should be understood to refer to Prime Number Acquisition I Corp.

Certain amounts and percentages that appear in this Report may not sum due to rounding.

Unless otherwise stated or unless the context otherwise requires, in this Report:

“3DOM Alliance” means 3DOM Alliance Inc., a company incorporated under the laws of Japan, which is the majority shareholder of noco-noco;

“Amended and Restated Memorandum and Articles of Association” means the amended and restated memorandum and articles of association of the Company adopted on August 18, 2023 and which took effect as of August 25, 2023;

“Business Combination” has the meaning ascribed to it in the section entitled “Explanatory Note.”;

“Business Combination Agreement” means the business combination agreement, dated December 29, 2022 (as may be amended, supplemented, or otherwise modified from time to time), by and among PubCo, PNAC, Merger Sub, New SubCo, noco-noco and certain shareholders of noco-noco;

“Closing” means the closing of the Business Combination;

“Closing Date” means the date of the Closing;

“ERF” means Emissions Reduction Fund, one of the schemes regulated by the CER;

“ESS” means energy storage system, a device or group of devices assembled together, capable of storing energy in order to supply electrical energy at a later time;

“JOBS Act” means the Jumpstart Our Business Startups Act of 2012;

“LOI” means letter of intent;

“Merger” means the merger between PNAC and Merger Sub, with PNAC being the surviving company and a wholly-owned subsidiary of PubCo;

“Merger Closing” means the closing of the Merger;

“Merger Effective Time” means the effective time of the Merger, being the time of the Certificate of Merger (as defined in the Business Combination Agreement) being accepted by the Secretary of State of the State of Delaware, or such later time as may be specified in the Certificate of Merger;

“Merger Sub” means Prime Number Merger Sub Inc., a Delaware corporation;

“MOU” means memorandum of understanding;

“Nasdaq” means the Nasdaq Capital Market;

“New SubCo” means Prime Number New Sub Pte. Ltd., a Singapore private company limited by shares;

“noco-noco” means NOCO-NOCO PTE. LTD., a Singapore private company limited by shares, or as the context requires, NOCO-NOCO PTE. LTD. and its subsidiaries and consolidated affiliated entities;

“noco-noco Shares” means the outstanding ordinary shares of noco-noco;

## Table of Contents

“noco-noco Valuation” means \$1,350,000,000;

“PNG” means Papua New Guinea;

“PubCo” means prior to the Closing, Prime Number Holding Limited, an exempted company limited by shares incorporated under the laws of the Cayman Islands; and upon and following the Closing, noco-noco Inc., an exempted company limited by shares incorporated under the laws of the Cayman Islands;

“PubCo Per Share Price” means the price per PubCo Ordinary Share that equal to the redemption price of each share of PNAC public share in connection with the Business Combination;

“Ordinary Shares” means the ordinary shares of the Company, having a par value of \$0.0001 each;

“R&D” means research and development;

“Registration Rights Agreement” means the registration rights agreement to be entered between PubCo, the Sponsors and certain shareholders of noco-noco pursuant to the Business Combination Agreement upon closing;

“SEC” means the U.S. Securities and Exchange Commission;

“Sellers” means the shareholders of noco-noco (immediately prior to the Share Exchange) participating in the Share Exchange. “shareholders” or “stockholders” means the holders of shares or stocks of a company;

“Share Exchange” means the transaction pursuant to which New SubCo will acquire issued and outstanding shares of noco-noco from the Sellers, in exchange, PubCo will issue to the Sellers the PubCo Ordinary Shares;

“Share Exchange Closing” means the closing of the Share Exchange;

“Singapore Dollars” and “S\$” means Singapore dollars, the legal currency of Singapore;

“Transaction Financing” means equity financing that, pursuant to the Business Combination Agreement, PubCo, PNAC and the New SubCo shall use reasonable best efforts to obtain, on the terms mutually agreed to by noco-noco and PNAC, in an amount that is at least \$20,000,000 prior to or upon the Share Exchange Closing; and

“U.S. Dollars,” “US\$” and “\$” means United States dollars, the legal currency of the United States;

“U.S. GAAP” means United States generally accepted accounting principles.

### **Frequently Used Technical Terms**

Unless otherwise stated or unless the context otherwise requires, in this Report:

“ACCUs” means Australian Carbon Credit Units, the national carbon credits issued by Australian regulators which can be obtained through establishing ERF projects;

“BEV” means battery electric vehicles, vehicles that exclusively use chemical energy stored in rechargeable battery packs; and “EV” means electric vehicles; and

“OEM” means original equipment manufacturer.



## CAUTIONARY NOTE REGARDING FORWARD-LOOKING STATEMENTS

This Report contains or may contain forward-looking statements as defined in Section 27A of the Securities Act, and Section 21E of the Exchange Act, that involve significant risks and uncertainties. All statements other than statements of historical facts are forward-looking statements. These forward-looking statements include information about our possible or assumed future results of operations or our performance. Words such as “expects,” “intends,” “plans,” “believes,” “anticipates,” “estimates,” and variations of such words and similar expressions are intended to identify the forward-looking statements, but absence of these words does not mean that a statement is not forward-looking. The risk factors and cautionary language referred to or incorporated by reference in this Report provide examples of risks, uncertainties and events that may cause actual results to differ materially from the expectations described in our forward-looking statements, including among other things, the matters set forth in the section entitled “Item 3. Key Information — D. Risk Factors” of this Report.

Readers are cautioned not to place undue reliance on these forward-looking statements, which speak only as of the date of this Report. Although we believe that the expectations reflected in such forward-looking statements are reasonable, there can be no assurance that such expectations will prove to be correct. These statements involve known and unknown risks and are based upon a number of assumptions and estimates which are inherently subject to significant uncertainties and contingencies, many of which are beyond our control. Actual results may differ materially from those expressed or implied by such forward-looking statements. We undertake no obligation to publicly update or revise any forward-looking statements contained in this Report, or the documents to which we refer readers in this Report, to reflect any change in our expectations with respect to such statements or any change in events, conditions or circumstances upon which any statement is based.

## [Table of Contents](#)

### PART I

#### ITEM 1. IDENTITY OF DIRECTORS, SENIOR MANAGEMENT AND ADVISERS

Not applicable.

#### ITEM 2. OFFER STATISTICS AND EXPECTED TIMETABLE

Not applicable.

#### ITEM 3. KEY INFORMATION

##### A. [Reserved]

##### B. Capitalization and Indebtedness

Not applicable.

##### C. Reasons for the Offer and Use of Proceeds

Not applicable.

##### D. Risk Factors

*Our business and our industry are subject to significant risks. You should carefully consider all of the information set forth in this Report and in our other filings with the SEC, including the following risk factors, in evaluating our business. If any of the following risks actually occur, our business, financial condition, operating results, and growth prospects would likely be materially and adversely affected. This Report also contains forward-looking statements that involve risks and uncertainties. See the section entitled "Cautionary Note Regarding Forward-Looking Information."*

##### Summary of Risk Factors

The following summary description sets forth an overview of the material risks we are exposed to in the normal course of our business activities. The summary does not purport to be complete and is qualified in its entirety by reference to the full risk factor discussion immediately following this summary description. We encourage you to read the full risk factor discussion carefully.

Our business, results of operations and financial condition could be materially and adversely affected by any of the following material risks:

- We are an early stage company with a history of financial losses and our battery business expects to incur significant expenses and continuing losses for the foreseeable future.
- Our business model has yet to be tested and any failure to commercialize our strategic plans would have an adverse effect on our operating results and business, harm our reputation and could result in substantial liabilities that exceed our resources.
- Our business plan may not prove successful, is subject to legal and regulatory risks and our products may not be well-accepted by the markets, which could materially and adversely affect our prospects.
- The success of our business significantly relies on our relationship with 3DOM Alliance. If 3DOM Alliance no longer exclusively licenses its intellectual property rights and technologies to us, our business, financial position, results of operations and prospect would be materially and adversely affected.
- Our business and future growth depends on the growth in demand for BEVs, hybrid vehicles and alternative fuel.
- The EV battery market continues to evolve and is highly competitive, and other battery manufacturers have significantly greater resources than we do.
- Our future success depends on the needs and success of our clients, as well as the demand for our clients' products or services.
- Many of our target clients are large commercial transportation companies, renewable energy plants and power plants, and the failure to maintain existing clients and secure new clients, withdrawal of leasing services by such clients or failure to negotiate acceptable terms in contract renewal negotiations could have an adverse impact on our business.
- We may not be able to engage target clients successfully and to convert such contacts into meaningful orders in the future.



## Table of Contents

- If we are unable to establish and maintain confidence in our long-term business prospects among clients and analysts and within our industry or are subject to negative publicity, then our financial condition, operating results, business prospects and access to capital may suffer materially.
- If any of our battery products fails to perform as expected, our ability to develop, market and sell our products and services could be harmed.
- Our battery products will require extensive safety testing prior to being offered to our lessees or installed in electric vehicles and power plants.
- Any decline in the value of carbon credits or carbon offsets could materially adversely affect our business.
- Changes in industry standards or practices for issuance or usage of carbon credits or carbon offsets could significantly adversely affect our business.
- We cannot guarantee that the approvals of the carbon abatement projects and issuing of Australian Carbon Credit Units (“ACCUs”) will not be revoked, cancelled or otherwise.
- Our operations and investments are located in Asia-Pacific and we are therefore exposed to various risks inherent in operating and investing in the region.

### **Risks Related to Our Business and Industry**

***We are an early stage company with a history of financial losses and our battery business expects to incur significant expenses and continuing losses for the foreseeable future.***

We are engaged in (i) leasing of battery products, including batteries, BEVs and ESS and (ii) carbon abatement solutions and carbon credit sales. Our business incurred a net loss of approximately \$1.1 million and \$16.8 million for the year ended June 30, 2022 and 2023, respectively, and an accumulated deficit of approximately \$2.4 million and \$19.1 million as of June 30, 2022 and 2023, respectively. As our battery business currently does not have any operations to generate revenue, except revenue generated in 2021 for production of sample batteries used for a client’s internal testing for the purpose of providing the Public Utility Board of Singapore with a proof-of-concept ESS, we believe that our battery business will continue to incur operating and net losses each fiscal year until such time as we begin significant production and leasing of our battery products, which is not expected to occur until the fourth quarter of 2024, and may occur later. Additionally, the revenue to be generated from carbon credit sales is dependent on the timing as to when the carbon abatement projects will be approved by the local government authorities.

We expect the rate at which we will incur losses to be higher in future periods as we, among other things, continue to expand our footprints in the Southeast Asia and South Asia region, increase our sales and marketing activities, develop our distribution infrastructure, and increase our general and administrative functions to support our growing operations. We may find that these efforts are more expensive than we currently anticipate or that these efforts may not result in revenues, which would further increase our losses or even prevent us from continuing as a going concern.

Further, the battery and EV industries are affected by market conditions that are outside our control. Our results of operations may fluctuate significantly from period to period due to a number of factors, including changes in market demand for batteries, BEVs and ESS, industry-wide technology changes, the loss of key clients and the postponement, rescheduling or cancellation of large orders by key clients. As a result of these factors and other risks discussed in this section, period-to-period comparisons should not be relied upon to predict our future performance.

***Our business model has yet to be tested and any failure to commercialize our strategic plans would have an adverse effect on our operating results and business, harm our reputation and could result in substantial liabilities that exceed our resources.***

Our battery business has not commenced operations yet. Investors should be aware of the difficulties normally encountered by a new enterprise, many of which are beyond our control, including substantial risks and expenses in the course of developing or manufacturing new products or services, establishing or entering new markets, organizing operations, and undertaking marketing activities. The likelihood of our success must be considered in light of these risks, expenses, complications, delays and the competitive environment in which we operate. There is, therefore, nothing at this time upon which to base an assumption that our business plan will prove successful, and we may not be able to generate significant revenue, raise additional capital, or operate profitably. We will continue to encounter risks and difficulties frequently experienced by early commercial stage companies, including introducing products or services that are accepted by the markets, scaling up our infrastructure and headcount, and we may encounter unforeseen expenses, difficulties or delays in connection with our growth. In addition, as a result of the capital-intensive nature of our leasing business, we can be expected to face pressures to raise additional financings in order to sustain our operations of leasing projects to grow our business and achieve profitability. Any investment in our company is therefore highly speculative and could result in the loss of your entire investment.



## [Table of Contents](#)

It is difficult to predict our future revenues and appropriately budget for our expenses, and we have limited insight into potential changes in trends that may emerge and affect our business. In the event that actual results differ from our estimates or we adjust our estimates in future periods, our operating results, prospects and financial position could be materially affected. The projected financial information appearing elsewhere in these materials was prepared by management and reflects current estimates of future performance. The projected results depend on the successful implementation of management's growth strategies and are based on assumptions and events over which we have only partial or no control. In particular, our projected results are heavily reliant on our ability to successfully develop, manufacture, market and lease our battery products. The assumptions underlying such projected information require the exercise of judgment and may not occur, and the projections are subject to uncertainty due to the effects of economic, business, competitive, regulatory, legislative, and political or other changes.

***Our business plan may not prove successful, is subject to legal and regulatory risks and our products may not be well-accepted by the markets, which could materially and adversely affect our prospects.***

Our businesses in Asia-Pacific, including Singapore, Thailand, Philippines, Indonesia, India, Australia, and PNG, are relatively new, and there is no assurance that we will be able to achieve and maintain growth and profitability across all of our business segments. There is also no assurance that our offerings will be accepted by the market or that market acceptance of our offerings will grow. Further, technologies and industry standards in relation to batteries, BEVs and ESS are evolving. For example, many of our competitors are developing a variety of battery technologies, such as solid state batteries and fuel cells, which are expected to compete with our existing product lines. It is possible that our competitors will be able to introduce new products with more desirable features than ours and their new products will gain greater market acceptance. In addition, our business could be impacted by macro-economic conditions and their effect on discretionary consumer spending, which could impact the business of our prospective consumers and in turn could impact the demand of service offerings made available by us.

Furthermore, we plan to operate our leasing services and carbon abatement solutions in several countries in the large, diverse and complex Asia-Pacific region. Each of our segments is subject to various regulations in each of the jurisdictions in which we operate. Focus areas of regulatory risk that we are exposed to include, among others: (i) evolution of laws and regulations applicable to the leasing of batteries, BEVs and ESS as well as carbon abatement projects and carbon credit sales, (ii) various forms of data regulation such as data privacy, data localization, data portability, cybersecurity and advertising or marketing, (iii) economic regulations such as price, supply regulation, safety, health, environment regulations, (iv) foreign ownership restrictions, (v) vehicle regulation, (vi) land management, and (vii) native title of land. In addition, we may not be able to obtain all the licenses, permits and approvals that may be necessary to provide our product or service offerings. Because the relevant laws and regulations, as well as their interpretations, are often unclear and evolving in certain jurisdictions, this can make it difficult for us to assess whether we have complied with the relevant laws and regulations and which licenses and approvals are necessary for our business, or the processes for obtaining such licenses in certain jurisdictions. For these reasons, we also cannot be certain that we will be able to comply with all the material laws and regulations or maintain the licenses and approvals that we have previously obtained, or that once they expire we will be able to renew them. We cannot be sure that our interpretations of the rules and their exemptions have always been or will be consistent with those of the local regulators. As we expand our businesses, we may be required to obtain new licenses and will be subject to additional laws and regulations in the markets we plan to operate in.

We also expect to expand our businesses in the Asia-Pacific region through acquisitions and strategic partnerships. Such expansion may increase the complexity of our business and may place significant strain on our management, personnel, operations, systems, technical performance, financial resources, and internal financial control and reporting functions. If our efforts of expansion through acquisitions or strategic partnerships fail, our business, results of operations, financial position, reputation, and prospects could be materially adversely affected.

***The success of our business significantly relies on our relationship with 3DOM Alliance. If 3DOM Alliance no longer exclusively licenses its intellectual property rights and technologies to us, our business, financial position, results of operations and prospect would be materially and adversely affected.***

All of our technologies are licensed from 3DOM Alliance, enabling us to utilize certain intellectual property rights and technologies owned or licensed in by 3DOM Alliance to manufacture and offer our own products. We also rely on 3DOM Alliance's intellectual property rights and technologies to enable the development, operations and improvement of our battery products. Although our license-in agreement with 3DOM Alliance has a perpetual term, 3DOM Alliance can terminate the license-in agreement if we fail to pay any amounts when due with a thirty (30) days' written notice, or when we fail to perform any obligation and fail to cure within the sixty (60) days notice period. If the license-in agreement is terminated or if we are unable to license future intellectual property rights and technologies from 3DOM Alliance, if we do so only on terms that are less favorable to us, our ability to continue to develop, maintain and improve our battery products and services could be harmed, which could in turn adversely affect our business, financial condition and results of operations. Additionally, some of the technology licensed under the 3DOM Alliance license are sublicensed to us by 3DOM (rather than licensed directly) and if 3DOM were to lose its rights to sublicense such technologies it is possible that we would not be able to use such technologies in the future.



## [Table of Contents](#)

### ***Our business and future growth depends on the growth in demand for BEVs, hybrid vehicles and alternative fuel.***

As the demand for our products is directly related to the market demand for BEVs, a fast-growing e-mobility market will be critical to the success of our business. However, the markets we have targeted, primarily those in Asia-Pacific region, may not achieve the level of growth we expect during the time frame projected. If any of these markets that we plan to expand into fails to achieve our expected level of growth, we may incur significant losses and not be able to generate enough revenue to achieve profitability. If the market for alternative fuel, hybrid vehicles and electric vehicles does not develop at the rate or in the manner or to the extent that we expect, or if critical assumptions that we have made regarding the efficiency of our energy solutions are incorrect or incomplete, our business, prospects, financial condition and operating results could be adversely affected.

### ***The EV battery market continues to evolve and is highly competitive, and other battery manufacturers have significantly greater resources than we do.***

The EV battery market, like the EV market it services, is fast-growing, extremely competitive and driven by the innovation of both large incumbents and emerging entrants like noco-noco. Lithium-ion battery technology has been widely adopted and our current competitors have, and future competitors may have, greater resources than we do and may also be able to devote greater resources to the development of their current and future technologies. These competitors also may have greater access to clients and may be able to establish cooperative or strategic relationships amongst themselves or with third parties that may further enhance their resources and competitive positioning. In addition, lithium-ion battery manufacturers may continue to reduce cost and expand supply of conventional batteries and, therefore reducing the prospects for our business or negatively impacting our ability to provide our products at a market-competitive price and with sufficient margins.

To date, we have focused our efforts on our state-of-the-art X-SEPA separator and lithium manganese iron phosphate (LMFP) cathode. However, a number of development-stage companies are also seeking to develop new technologies for lithium-metal batteries, such as new technologies for cathodes, anodes, electrolytes and additives. Some of these companies have established relationships with OEMs and are in varying stages of development. Additionally, many OEMs are researching and investing in conventional lithium-ion batteries and/or lithium-metal battery efforts and, in some cases, in battery development and production. Furthermore, other companies are developing alternative technologies such as advanced diesel, ethanol, fuel cells or compressed natural gas, as well as potential improvements in the fuel economy of the internal combustion engine. We expect competition in battery technology and BEVs to intensify due to increased demand for EVs. Competition may also be driven by a regulatory push for EVs, continuing globalization, and consolidation in the worldwide automotive industry. Developments in alternative technologies or improvements in battery technology made by competitors may materially adversely affect the sales, pricing and gross margins of our battery products. If a competing technology is developed that has superior operational or price performance, our business will be harmed. Similarly, if we fail to accurately predict and ensure that our battery technology can address clients' changing needs or emerging technological trends, or if our clients fail to achieve the benefits expected from our battery products, our business will be harmed.

### ***Our future success depends on the needs and success of our clients, as well as the demand for our clients' products or services.***

The demand for our battery products, in particular the batteries and BEVs, will ultimately depend on our clients, consisting primarily of commercial transportation companies, renewable energy plants and power plants. Decisions to purchase or lease our batteries and BEVs may depend on the performance of the industries of our clients and if demand for output in those industries decreases, then the demand for our products may decrease as well. Demand in these industries is impacted by numerous factors, including, but not limited to, commodity prices, infrastructure spending, fuel costs, energy demands, municipal spending and government mandates and incentives. Increases or decreases in these variables may significantly impact the demand for our products.

### ***Many of our target clients are large commercial transportation companies, renewable energy plants and power plants, and the failure to maintain existing clients and secure new clients, withdrawal of leasing services by such clients or failure to negotiate acceptable terms in contract renewal negotiations could have an adverse impact on our business.***

Although we intend to lease predominantly to commercial transportation companies, renewable energy plants and power plants, we may not be able to establish or continue our relationships with such commercial transportation companies, renewable energy plants or power plants, if customer demand is not as high as we expect or if they face pressure or contractual obligations from their existing suppliers not to purchase our products or services. We may enter into long-term contracts with certain of these commercial transportation companies, renewable energy plants and power plants, who have substantial bargaining power with respect to price and other commercial terms, and any long-term contracts would be subject to renegotiation and renewal from time to time. Failure to maintain existing clients, obtain new clients, loss of all or a substantial portion of sales to any future clients for whatever reason (including, but not limited to, loss of contracts or failure to negotiate acceptable terms in contract renewal negotiations, loss of market share by these clients, insolvency of such clients, reduced or delayed client requirements, plant shutdowns, strikes or other work stoppages affecting production by such clients) or continued reduction of prices to these clients could have a significant adverse effect



on our financial results and business prospects. There can be no assurance that we will be able to maintain existing clients, obtain new clients or secure new contracts.

## [Table of Contents](#)

The level of any future leasing to commercial transportation companies, renewable energy plants and power plants, including the realization of future leasing services from awarded business or obtaining new business or clients, is inherently subject to a number of risks and uncertainties, including the number of vehicles, energy storage or grid stabilization that these commercial transportation companies, renewable energy plants and power plants actually need. Further, to the extent that the financial condition, including bankruptcy or market share, of any of our largest clients deteriorates or their sales otherwise continue to decline, our business, prospects, financial condition and operating results could be adversely affected. Accordingly, we may not in fact realize all of the future sales represented by our awarded business. Any failure to realize these sales could have a material adverse effect on our business, prospects, financial condition and operating results.

***We may not be able to engage target clients successfully and to convert such contacts into meaningful orders in the future.***

Our success, and our ability to increase revenue and operate profitably, depends in part on our ability to identify target clients and convert target clients into meaningful orders or expand on client relationships. In some cases, certain clients will purchase our battery product samples on an early trial deployment basis, where such clients have the ability to test and evaluate whether our products meet their performance requirements before such clients commit to meaningful orders.

Our future success depends on whether our target clients are willing to use our battery products as well as whether their product lines will incorporate our battery products. If our target clients expand their product lines, we hope to be the primary supplier for their BEVs. Competition in our industry is high. To secure acceptance of our products, we must constantly develop and introduce longer-range and more cost-effective batteries with enhanced functionality and performance to meet evolving industry standards. If we are unable to meet our clients' performance requirements or industry specifications, retain or engage with target clients, or convert early trial deployments into meaningful orders, our business, prospects, financial condition and operating results could be materially adversely affected.

***If we are unable to establish and maintain confidence in our long-term business prospects among clients and analysts and within our industry or are subject to negative publicity, then our financial condition, operating results, business prospects and access to capital may suffer materially.***

Clients may be less likely to purchase our battery products if they are not convinced that our business will succeed or that our service and support and other operations will continue in the long term. Similarly, suppliers and other third parties will be less likely to invest time and resources in developing business relationships with us if they are not convinced that our business will succeed. Accordingly, in order to build and maintain our business, we must earn and maintain confidence among clients, suppliers, analysts, ratings agencies and other parties in our products, long-term financial viability and business prospects. Maintaining such confidence may be particularly complicated by certain factors including those that are largely outside of our control, such as our limited operating history, client unfamiliarity with our battery products, any delays in scaling production, delivery and service operations to meet demand, competition, future changes in the evolving hybrid electric and electric vehicle market or uncertainty regarding our production and sales performance compared with market expectations.

***If any of our battery products fails to perform as expected, our ability to develop, market and sell our products and services could be harmed.***

Our battery products, such as our batteries, BEVs, and ESS, could contain defects in design and production that may cause them not to perform as expected or may require repair. We currently have a limited frame of reference by which to evaluate the performance of our products upon which our business prospects depend. There can be no assurance that we will be able to detect and fix any defects in our battery products. We may experience recalls in the future, which could adversely affect our brand and could adversely affect our business, prospects, financial condition and operating results.

Further, our products may not perform consistent with clients' expectations. Any product defects or any other failure of our battery products to perform as expected could harm our reputation and result in lost revenue, delivery delays, product recalls, negative publicity, product liability claims and significant warranty and other expenses and could have a material adverse impact on our business, prospects, financial condition and operating results. Additionally, problems and defects experienced by alternative fuel commercial vehicle companies or electric consumer vehicles could by association have a negative impact on public perception and customer demand for our products.

***Our battery products will require extensive safety testing prior to being offered to our lessees or installed in electric vehicles and power plants.***

To achieve acceptance by our clients, including lessees, and power producers, our anticipated batteries, BEVs and ESS will have to undergo extensive safety testing. We plan to conduct preliminary safety testing for design verification of our battery products at their prototype stage. We are also subject to safety tests for product validation to obtain various safety standard certifications before

commencing mass production of our battery products. There can be no assurance that such tests will be successful, and we may identify different or new safety issues in our development or manufacturing of the batteries, BEVs and ESS that have not been present

## [Table of Contents](#)

in our prototypes. If we have to make design changes to address any safety issues, we may have to delay or suspend commercialization, which could materially damage our business, prospects, financial condition, operating results and brand.

### ***Any decline in the value of carbon credits or carbon offsets could materially adversely affect our business.***

The value of carbon credits and carbon offsets fluctuate based on market, standard-setting and regulatory forces outside our control. Although the value of carbon credits and carbon offsets has been rising in recent years, new technologies or easier carbon credit or carbon offset issuance rules, for example, may facilitate an increase in the supply of carbon credits and carbon offsets that outstrips demand, resulting in the value of carbon credits and carbon offsets to decline. Any such decline could mean demand and pricing for our carbon credit supply offerings would be adversely affected. Apart from supply and demand, the carbon credits prices may also be impacted by micro-and macro-economic conditions, general economic sentiment, international mandates, geopolitical tension, technology enhancements, inflation and currency exchange rates. Any decline in the value of carbon credits or carbon offsets could materially and adversely affect our business, results of operations and financial condition.

### ***Changes in industry standards or practices for issuance or usage of carbon credits or carbon offsets could significantly adversely affect our business.***

The issuance and verification procedures, and the recommended usage, for carbon credits or carbon offsets are evolving areas. Changes in these areas could materially and adversely impact our business. Should, for example, issuance standards change such that our carbon-focused projects are not able to issue as many carbon credits or carbon offsets as projected, our available carbon credit pool will decline which will materially negatively impact our business. The demand side of the carbon credit markets are driven by a combination of industry standards and generally accepted practices and regulations. Should industry practices or recommendations change, or the regulatory environment change, there could be a potentially material and adverse effect on our business.

### ***If verified and available carbon sequestration or carbon credits or carbon offsets are lower than projected, our business could be materially adversely affected.***

We may make estimates on future carbon potential for our carbon abatement projects, specifically including nature-based projects such as reforestation (or other similar projects such as changes in soil or land management). We may rely on these and other generally available estimates for making carbon neutrality calculations, tree planting commitments and/or carbon credits sales or carbon offsets. If the actual realized carbon sequestration differs from our estimates due to factors, such as differences in survival rates or measured carbon sequestration, or changes in verification methodologies, standards, or changes in required buffer pools (including by third-party verification organizations), fewer carbon sequestration, carbon credits or carbon offsets may be realized and available, which could negatively impact our business and profitability as carbon credits and carbon offsets earned by us may be reduced and we may be required to purchase carbon credits at prevailing market rates.

### ***We cannot guarantee that the approvals of the carbon abatement projects and issuing of Papua New Guinea Carbon Credits and Australian Carbon Credit Units (“ACCUs”) will not be revoked, cancelled or otherwise.***

We operate our carbon abatement solutions in a variety of Oceanian countries, including Australia and PNG. In Australia, the carbon abatement projects and the issuing of ACCUs are subject to the approvals and regulation of the Australian government and in particular, the Clean Energy Regulator (the “CER”). Prior to issuing ACCUs, the CER reviews and considers applications for approved projects. We cannot guarantee that such approvals and issuing of ACCUs will not be revoked, cancelled or otherwise negatively impacted, in which case our business could be materially adversely affected.

Furthermore, the regulatory bodies may impose further compliance procedures and protocols on our existing or future projects. Any such procedures or protocols will require us to adopt and incorporate any amendments to ensure full and complete compliance of law and regulations. This may result in the delay of carrying out our existing projects, and may also impact the development of our future business activities. The regulation of the ACCUs is subject to government policy changes, and we cannot guarantee that our current business activities will not be impacted by any future amendments to laws and regulations governing the carbon abatement industry.

### ***If we cannot acquire all interested parties’ consent for the carbon abatement projects, or if there is any deficiency in the ownership interests in the properties of the projects, our business could be materially adversely affected.***

The carbon abatement project procurement stage may involve several parties with varying interests, which mainly includes landowners, but sometimes also a bank or a lending institution if there is a mortgage on the property to obtain consent or a “no objection certificate” from the lender to file and obtain carbon credits. For certain carbon abatement projects, we may not only need to obtain consent from a single landowner but multiple landowners to tie up contiguous land parcels for carrying out such projects. When we negotiate with the interested parties, we cannot guarantee that we are able to acquire the consent from all of them. If we are not able to do so, the projects will not be carried out according to the planned timetable, and our business could be materially adversely

affected. In addition, if there is any deficiency or controversy in the title or ownership of any property which is the subject of a carbon abatement project, we will need to seek to ensure our legitimate business interests as protected, which may result in

## [Table of Contents](#)

limiting the resources being applied to our business activities. Furthermore, if we are unsuccessful in protecting our legitimate business interests, our business operations could be materially adversely affected.

### ***Any non-compliance of the landowners on their contractual obligations may affect our carbon abatement solutions business.***

Due to the growth of our carbon abatement projects requiring large areas of land, access to land is an integral part of our business activities. In particular, unrestricted access to use and control the land is important to maintain and further our business activities. However, we are generally not the registered owner of any real property, and entirely rely on the licenses and/or agreements in place with the registered landowners and their compliance with their respective contractual obligations. If the landowners do not have valid licenses or approvals, or do not comply with legal requirements or contractual obligations, we may not be able to maintain the necessary rights required for our business activities and therefore it could affect our business operations.

### ***We may not succeed in establishing, maintaining and strengthening our brand, which would materially and adversely affect client acceptance of our technologies and our business, revenues and prospects.***

Our business and prospects depend on our ability to develop, maintain and strengthen our brand. If we are not able to establish, maintain and strengthen our brand, we may lose the opportunity to build a critical mass of clients. The battery and EV industry is intensely competitive, and we may not be successful in building, maintaining and strengthening our brand. Our potential competitors, including many battery manufacturers and automotive OEMs around the world, have greater name recognition, broader client relationships and substantially greater marketing resources than we do. If we do not develop and maintain a strong brand, our business, prospects, financial condition and operating results will be materially and adversely impacted.

### ***We operate in an extremely competitive industry and are subject to pricing pressures. Further, many other battery manufacturers have significantly greater resources than we do.***

We compete with a number of major international manufacturers and distributors, as well as a number of smaller, regional competitors. We expect competition to become more intense as zero-emission transportation is becoming the mainstream with an increasing number of participants in the industry. Increased competition may result in declines in average selling prices, causing a decrease in margins. Due to excess capacity in some sectors of our industry and consolidation among industrial battery purchasers, we may be subjected to significant pricing pressures.

Many of our competitors have greater financial, personnel, technical, manufacturing, marketing, sales and other resources than we do, which may place us at a competitive disadvantage. In addition, certain of our competitors may have a lower overall cost structure. As a result, these competitors may be in a stronger position to respond quickly to market opportunities, new or emerging technologies and evolving industry standards. Many of our competitors are developing a variety of battery technologies, such as solid state batteries and fuel cell, which are expected to compete with our existing product lines. It is possible that our competitors will be able to introduce new products with more desirable features than ours and their new products will gain greater market acceptance. If our competitors successfully do so, we may not be able to maintain our competitive position and our business and future success would be materially and adversely affected.

We anticipate continued competitive pricing pressure as other producers may be able to employ labor at significantly lower costs, expand their export capacity and increase their marketing presence in our major end markets. Several of our competitors have strong technical, marketing, sales, manufacturing, distribution and other resources, as well as significant name recognition, established positions in the market and long-standing relationships with our industry's potential client base. In addition, certain of our competitors may have long-standing relationships with suppliers, which may provide them with a competitive pricing advantage and reduce their exposure to volatile raw material costs. Our ability to maintain and improve our operating margins has depended, and continues to depend, on our ability to control and reduce our costs. We cannot assure you that we will be able to continue to control our operating expenses, to raise or maintain our prices or increase our unit volume, in order to maintain or improve our operating results.

### ***The uncertainty in global economic conditions could negatively affect our operating results.***

Our operating results are directly affected by the general global economic conditions of the industries in which our major client groups operate. Our business segments are highly dependent on the economic and market conditions in each of the geographic areas in which we operate. Leasing of our batteries, BEVs and ESS, for example, depend significantly on demand for new electric vehicle transportation or ride-sharing companies. The uncertainty in global economic conditions varies by geographic segment and can result in substantial volatility in global credit markets. These conditions affect our business by reducing prices that our clients may be able or willing to pay for our products or by reducing the demand for our products, which could in turn negatively impact our sales and result in a material adverse effect on our business, cash flow, results of operations and financial condition.

## [Table of Contents](#)

### ***Substantial increases in the prices for our raw materials and components, some of which are obtained from a limited number of sources where demand may exceed supply, could materially and adversely affect our business.***

We rely on third-party suppliers for components and equipment necessary to develop our products, including key supplies, such as polyimide substrate, organic beads, LMFP cathode material and separator manufacturing machine, for our battery products. We face risks relating to the availability of these materials and components, including that we will be subject to demand shortages and supply chain challenges, especially in the context of the current COVID-19 pandemic, and generally may not have sufficient purchasing power to eliminate the risk of price increases for the raw materials and tools we need. Further, certain components, including drying furnace, 3-layer die, charging and discharging equipment, IC chips and CPUs, have a long lead time which require us to order well in advance to support our proposed commercial operations. To mitigate the supply chain risks, we are adopting an all-round strategy of collaborating with many automaker partners and OEM suppliers. However, to the extent that we are unable to enter into commercial agreements with our prospective suppliers or our replacement suppliers on favorable terms, or these suppliers experience difficulties meeting our requirements, the development and commercial progression of our battery products and related technologies may be delayed.

Separately, we may be subject to various supply chain requirements regarding, among other things, conflict minerals and labor practices. We may be required to incur substantial costs to comply with these requirements, which may include locating new suppliers if certain issues are discovered. We may not be able to find any new suppliers for certain raw materials or components required for our operations, or such suppliers may be unwilling or unable to provide us with products.

Any disruption in the supply of components, equipment or materials could temporarily disrupt production of our battery product until an alternative supplier is able to supply the required material. Changes in business conditions, unforeseen circumstances, governmental changes, and other factors beyond our control or which we do not presently anticipate, could also affect our suppliers' ability to deliver components or equipment to us on a timely basis. Any of the foregoing could materially and adversely affect our results of operations, financial condition and prospects.

Currency fluctuations, trade barriers, tariffs or shortages and other general economic or political conditions may limit our ability to obtain key components or equipment for our battery products or significantly increase freight charges, raw material costs and other expenses associated with our business, which could further materially and adversely affect our results of operations, financial condition and prospects.

### ***Entering into strategic alliances could expose us to risks.***

We have entered into several memorandums of understanding ("MOUs") for, and may in the future enter into additional, strategic alliances, including joint ventures or minority equity investments, with various third parties to further our business.

While offering potential benefits, these strategic alliances could subject us to a number of risks, including risks associated with sharing proprietary information, non-performance by the partners and increased expenses in establishing new strategic alliances, any of which may materially and adversely affect our business. We may have limited ability to monitor or control the actions of these partners and, to the extent any of these strategic partners suffers negative publicity or harm to their reputation from events relating to their business, we may also suffer negative publicity or harm to our reputation by virtue of our association with any such partner. For example, if we rely on certain strategic partner's manufacturing facilities to produce our battery products, those operations would be outside of our control. We could experience delays if our partners do not meet agreed upon timelines, satisfy legal, industry or our client's requirements, or experience capacity constraints, and in turn, we could lose clients and face reputational harm.

Further, there is risk of potential disputes with the strategic partners, and we could be affected by adverse publicity related to our partners whether or not such publicity is related to their collaboration with us. Our ability to successfully build a premium brand could also be adversely affected by perceptions about the quality of our partners' products. Our OEM partners may also have economic, business, or legal interests or goals that are inconsistent with ours. As a result, it may be challenging for us to resolve issues that arise in respect of the performance of our agreements or MOUs with them, and such issues might impact development work underway under the agreements or MOUs.

Any significant disagreements with them, and especially if we become dependent on that OEM partner for our research and development efforts, may impede our ability to maximize the benefits of our partnerships and slow the commercial roll-out of our battery products. In addition, if our partners are unable or unwilling to meet their economic or other obligations under the agreements or MOUs, we may be required to fulfill those obligations alone, which could delay research and development progress and otherwise negatively impact our business and financial results. Furthermore, the relationships we have with our existing partners and the rights our partners have under their respective agreements or MOUs, may deter other OEMs from working with us. If we are not able to establish or expand our partnership with other OEMs, our business and prospects could be materially harmed.





## [Table of Contents](#)

***We are dependent on our suppliers to fulfill our clients' orders, and if we fail to manage our relationships effectively with, or lose the services of, these suppliers and cannot substitute suitable alternative suppliers, our operations would be materially adversely affected.***

We rely on our suppliers for the provision of raw materials, automaker partners and OEM suppliers for the manufacturing of our battery products, including battery separators, cells and packs, BEVs and ESS. While we plan to engage multiple suppliers, automakers and OEMs whenever possible, the inability of our suppliers to deliver the raw materials and battery products manufactured by them at prices, volumes, performance and specifications acceptable to us could have a material adverse effect on our business, prospects, financial condition and operating results. In addition, because we rely on our suppliers and partners to provide raw materials or manufacture battery products that meet our quality standards, there can be no assurance that we can successfully receive quality materials or products from our suppliers and partners that satisfy our quality standards. Any of the foregoing could adversely affect our business, results of operations, financial condition and prospects.

***Our failure to keep up with rapid technological changes and evolving industry standards may cause our products to become obsolete and less marketable.***

The battery market is characterized by changing technologies and evolving industry standards, which are difficult to predict. This, coupled with frequent introduction of new products and models, has shortened product life cycles and may render our products obsolete or unmarketable. Our ability to adapt to evolving industry standards and anticipate future standards and market trends will be a significant factor in maintaining and improving our prospects for growth. R&D activities, however, are inherently uncertain and require significant costs, and we might encounter practical difficulties in commercializing our new technologies licensed from 3DOM Alliance. On the other hand, our competitors may improve their technologies or even achieve technological breakthroughs that would render our products obsolete or less marketable. Therefore, our failure to effectively keep up with rapid technological changes and evolving industry standards by introducing new and enhanced products may cause us to lose our clients and to suffer a decrease in our revenue.

***If we cannot continue to develop new products in a timely manner and at favorable margins, we may not be able to compete effectively.***

The battery industry has been notable for the pace of innovations in product life, product design and applied technology. We and our competitors have made and continue to make, investments in innovating and improving our products. Our ability to create new products and line extensions and to sustain existing products is affected by whether we can, among other things:

- license-in on favorable terms and maintain innovative intellectual property and technologies from 3DOM Alliance and its licensors;
- obtain governmental approvals and registrations;
- comply with governmental regulations; and
- anticipate client needs and preferences successfully.

The failure to develop and launch successful new products and any delay in the development or launch of a new product could hinder the growth of our business. In addition, if competitors introduce new or enhanced products that significantly outperform ours, or if they develop or apply manufacturing technology that permits them to manufacture at a significantly lower cost relative to ours, we may be unable to compete successfully in the market segments affected by these changes.

***We may obtain licenses on technology that has not been commercialized or has been commercialized only to a limited extent, and the success of our business may be adversely affected if such technology does not perform as expected.***

From time to time, we may license from third parties, including 3DOM Alliance, technologies that have not been commercialized or which have been commercialized only to a limited extent. These technologies may not perform as expected within the markets for our battery products. If the cost, performance characteristics, manufacturing process or other specifications of these licensed technologies fall short of our targets, our projected sales, costs, time to market, future product pricing and potential operating margins may be adversely affected.

***Developments in alternative technology may adversely affect the demand for our battery products.***

Significant developments in alternative technologies, such as advanced diesel, ethanol or natural gas, or breathing batteries, may materially and adversely affect our business, prospects, financial condition and operating results in ways that we may not currently anticipate. Existing and other battery technologies, fuels or sources of energy may emerge as clients' preferred alternatives to our battery products. Any failure by us to develop new or enhanced technologies or processes, or to react to changes in existing

technologies, could materially delay our development and introduction of new and enhanced alternative products, which could result in decreased revenue and a loss of market share to our competitors.

## [Table of Contents](#)

We rely on 3DOM Alliance's R&D efforts which may not be sufficient to adapt to changes in alternative fuel and electric vehicle technology. As technologies evolve, we will need to upgrade or adapt our clean energy solutions with the latest technology, in particular our licensed-in long-life battery technology, and developing intelligent battery systems with CPUs and Internet of Things (IoT) devices attached, in order to leverage on our own-and-lease model. However, we may not compete effectively with alternative systems if we are not able to source and integrate the latest technology into our battery products.

***Our products could have undetected defects, errors or bugs in hardware, firmware or software, which could reduce market adoption, damage our reputation with prospective clients, and/or expose us to product liability and other claims that could materially and adversely affect our business.***

We may be subject to claims that our products have malfunctioned and persons were injured or purported to be injured due to latent defects. Any insurance that we carry may not be sufficient or it may not apply to all situations. Similarly, to the extent that such malfunctions are related to components obtained from third-party vendors, such vendors may not assume responsibility for such malfunctions. Any of these events could adversely affect our brand, reputation, financial condition or results of operations.

Any defects or errors in product or services offerings, or the perception of such defects or errors, or other performance problems could result in any of the following, each of which could adversely affect our business and results of operations:

- expenditure of significant financial and product development resources, including recalls, in efforts to analyze, correct, eliminate or work around errors or defects;
- loss of existing or potential clients or partners;
- interruptions or delays in sales;
- equipment replacements;
- delayed or lost revenue;
- delay or failure to attain market acceptance;
- delay in the development or release of new functionality or improvements;
- negative publicity and reputational harm;
- sales credits or refunds;
- exposure of confidential or proprietary information;
- diversion of development and client service resources;
- breach of warranty claims;
- legal claims under applicable laws, rules and regulations; and
- the expense and risk of litigation.

We also face the risk that any contractual protections we seek to include in our agreements with clients are rejected, not implemented uniformly or may not fully or effectively protect from claims by clients, business partners or other third parties. In addition, any insurance coverage or indemnification obligations of suppliers for our benefit may not adequately cover all such claims, or cover only a portion of such claims. A successful product liability, warranty, or other similar claim could have an adverse effect on our business, financial condition and results of operations. In addition, even claims that ultimately are unsuccessful could result in expenditure of funds in litigation, divert management's time and other resources and cause reputational harm.

***We are subject to risks relating to production scale manufacturing of our battery products, including battery separators, cells and packs, BEVs and ESS through partners in the longer term.***

Our business plan contemplates that automakers and OEMs will manufacture our battery products, including battery separators, cells and packs, BEVs, and ESS, using our unique pre-calculated and calibrated manufacturing process. However, modifying or constructing these lines for production of our products could be more complicated or present significant challenges to our manufacturing partners that we do not currently anticipate. As with any large-scale capital project, any modification or construction of this nature could be subject to delays, cost overruns or other complications. Any failure to commence commercial production on schedule likely would lead to additional costs and could delay our ability to generate meaningful revenues. In addition, any such delay could diminish any "first mover" advantage we aim to attain, prevent us from gaining the confidence of OEMs and open the door to increased competition. All of the foregoing could hinder our ability to successfully launch and grow our business and achieve a competitive position in the market.



## [Table of Contents](#)

Further, collaboration with third parties to manufacture our battery products reduces our level of control over the process. We could experience delays if our partners do not meet agreed upon timelines or experience capacity constraints. There is risk of potential disputes with partners, which could stop or slow production, and we could be affected by adverse publicity related to our partners, whether or not such publicity is related to such third parties' collaboration with us. In addition, we cannot guarantee that our suppliers will not deviate from agreed-upon quality standards.

We may be unable to enter into agreements with manufacturers on terms and conditions acceptable to us and therefore we may need to contract with other third parties or create our own commercial production capacity. We may not be able to engage other third parties or establish or expand our own production capacity to meet our needs on acceptable terms, or at all. The expense and time required to adequately complete any transition may be greater than anticipated. Any of the foregoing could adversely affect our business, results of operations, financial condition and prospects.

### ***Manufacturing or use of our products may cause accidents, which could result in significant production interruption, delay or claims for substantial damages.***

Due to the high energy density inherent in lithium-based batteries, our batteries can pose certain safety risks, including the risk of fire or explosion. Our battery risk management system provides early warning signals of battery faults or malfunction, but accidents causing death or personal injury or property damage can still occur. Although safety procedures is also incorporated in the research, development, manufacture and transportation of batteries that are designed to minimize safety risks, the manufacture or use of our products may still cause accidents. Any accident, whether occurring at the manufacturing facilities or from the use of our products, may result in significant production interruption, delays or claims for substantial damages caused by personal injuries or property damage.

### ***We are subject to regulations regarding the storage and handling of various products. We may become subject to product liability claims, which could harm our financial condition and liquidity if we are not able to successfully defend or insure against such claims.***

We may become subject to product liability claims which could harm our business, prospects, operating results, and financial condition. We face inherent risk of exposure to claims in the event our batteries do not perform as expected or malfunction resulting in personal injury or death. Our risks in this area are particularly pronounced given our X-SEPA separator and lithium manganese iron phosphate (LMFP) cathode are still in the development stage and have not yet been commercially mass produced. A successful product liability claim against us could require us to pay a substantial monetary award. Moreover, a product liability claim could generate substantial negative publicity about our technology and business and inhibit or prevent commercialization of our battery products and future product candidates, which would have a material adverse effect on our brand, business, prospects and operating results. Any insurance coverage might not be sufficient to cover all potential product liability claims. Any lawsuit seeking significant monetary damages either in excess of our coverage, or outside of our coverage, may have a material adverse effect on our reputation, business and financial condition. We may not be able to secure product liability insurance coverage on commercially acceptable terms or at reasonable costs when needed.

### ***Our BEVs and our batteries as components of BEVs are subject to motor vehicle standards and the failure of the vehicles to satisfy such mandated safety standards could have a material adverse effect on the demand for our products, our business and our operating results.***

All vehicles and batteries installed in the vehicles sold or leased must comply with applicable international and local motor vehicle safety standards, which vary by national and local jurisdictions. Rigorous testing and the use of approved materials and equipment are among the requirements for achieving certain mandatory certifications. Failure by our vehicle manufacturing clients to satisfy motor vehicle standards could have a material adverse effect on our business and operating results.

Moreover, we may incur our own significant costs in complying with these regulations. Regulations related to the electric vehicle industry and alternative energy are currently evolving and we face risks associated with the application of these regulations and changes to these regulations.

To the extent the laws become more stringent or otherwise change, our BEVs and/or our batteries may not comply with applicable international or local laws, which would have an adverse effect on our business. Compliance with changing regulations could be burdensome, time consuming, and expensive. To the extent compliance with new regulations is cost prohibitive, our business, prospects, financial condition and operating results would be adversely affected.

There may be laws in jurisdictions we have not yet entered or laws of which we are unaware in jurisdictions we have entered that may restrict our sales or other business practices. Even for those jurisdictions we have analyzed, the laws in this area can be complex, difficult to interpret and may change over time. Continued regulatory limitations and other obstacles interfering with our or

our client's ability to sell products could have a negative and material impact on our business, prospects, financial condition and results of operations.

## [Table of Contents](#)

### ***Future product recalls could materially adversely affect our business, prospects, financial condition and operating results.***

Any product recall in the future, whether it involves our or a competitor's product, may result in negative publicity, damage our brand and materially adversely affect our business, prospects, financial condition and operating results. In the future, we may voluntarily or involuntarily, initiate a recall if any of our products that are proven or possibly could be defective or noncompliant with applicable federal motor vehicle safety standards. Such recalls involve significant expense and diversion of management attention and other resources, which could adversely affect our brand image, as well as our business, prospects, financial condition and operating results.

### ***We were granted the exclusive license on certain patents and other pending patent applications from 3DOM Alliance pursuant to a license-in agreement entered into on November 22, 2022. The pending patent applications under such license-in agreement may not result in issued patents and the licensed patents may be invalidated or narrowly interpreted, in which event our competitiveness and value may be undermined.***

Our key technological innovations, including innovations that are currently commercialized in our products and innovations that we plan to deploy in the future, are described in numerous issued patents and pending patent applications that we licensed from 3DOM Alliance. There is no assurance that the pending applications will result in issued patents. Further, we cannot guarantee that our use of these patents and associated inventions will not infringe upon rights of third parties. Also, to the extent that we endeavor to enforce our currently issued licensed patents or any patents that will be issued in the future, an alleged infringer may be able to assert that it has not infringed any claim of the applicable patent(s) and that the applicable patent(s) is in any event invalid or unenforceable. There can be no assurance that we will overcome those defenses. Further, if one or more of our patents are held to be invalid or unenforceable, or if claims of those patents are interpreted narrowly, or if patents fail to issue from our pending applications, our competitiveness and value may be undermined.

### ***We rely heavily on the exclusively-licensed intellectual properties and technologies, which includes patent rights, trade secrets, trademarks, and know-how. If we are unable to protect and maintain access to these intellectual property rights, our business and competitive position would be harmed.***

We may not be able to prevent unauthorized use of our exclusively-licensed intellectual property, which could harm our business and competitive position. We rely on a combination of the intellectual property protections afforded by patent, trademark and trade secret laws in Japan, Singapore and other jurisdictions, as well as license agreements and other contractual protections, to establish, maintain and enforce rights and competitive advantage in our licensed-in technologies. Third parties, including our business partners, may attempt to copy or otherwise obtain and use our intellectual property without our consent or may decline to license or defend necessary intellectual property rights to us on terms favorable to our business. Third parties may also attempt to challenge our use of certain intellectual property rights, particularly in countries where we do not hold patent rights. Monitoring unauthorized use of our intellectual property is difficult and costly, and the steps we have taken or will take to prevent misappropriation may not be sufficient. Any enforcement efforts we undertake, including litigation, could require involvement of the licensor, be time-consuming and expensive, and could divert management's attention, all of which could harm our business, results of operations and financial condition. In addition, existing intellectual property laws and contractual remedies may afford less protection than needed to safeguard our licensed-in technologies. All of our patent rights have been obtained through an exclusive license-in agreement from 3DOM Alliance. Because we do not own those patent rights, we have less control over their validity, maintenance and enforcement, which could harm our ability to maintain any competitive advantage those patent rights provide.

Any registrations for the intellectual property rights we own or license are constrained to the country in which the rights were issued or obtained. Many of the patents we license are not yet registered and are currently under review by the respective patent offices. Our efforts to protect against the unauthorized use of our intellectual property rights, technology and other licensed-in rights in those countries where our intellectual property is under review or not registered may be impossible. With respect to jurisdictions where our intellectual property is already registered, patent, copyright, trademark and trade secret laws vary significantly throughout the world. A number of foreign countries do not protect intellectual property rights to the same extent as Japan and Singapore. Therefore, our intellectual property rights may not be as strong or as easily enforced in some foreign countries, and efforts to protect against the unauthorized use of our intellectual property rights, technology and other licensed-in rights may be impossible in those countries. Failure to adequately protect or be able to use our exclusively-licensed intellectual property rights could result in our competitors using our intellectual property to offer products, potentially resulting in the loss of some of our competitive advantage, a decrease in our revenue and reputational harm caused by inferior products offered by third parties, which would adversely affect our business, prospects, financial condition and operating results.

### ***We are unable to guarantee that our technology, or its ultimate integration into electric vehicle battery packs, does not infringe intellectual property rights of third parties. We may need to defend ourselves against intellectual property infringement claims, which may be time-consuming and could cause us to incur substantial costs.***

Companies, organizations or individuals, including our current and future competitors, may hold or obtain patents, trademarks or other proprietary rights that would prevent, limit or interfere with our ability to make, use, develop, sell, license, lease or market our products or technologies, which could make it more difficult for us to operate our business. From time to time, we may receive inquiries from third parties relating to whether we are infringing their intellectual property rights and/or seek court declarations that



## [Table of Contents](#)

they do not infringe upon our intellectual property rights. Companies holding patents or other intellectual property rights relating to batteries may bring suits alleging infringement of such rights or otherwise asserting their rights and seeking licenses. In addition, if we are determined to have infringed upon a third party's intellectual property rights, we may be required to do one or more of the following:

- cease selling, leasing, incorporating or using products that incorporate the challenged intellectual property;
- pay substantial damages;
- materially alter our research and development activities and proposed production processes;
- obtain a license from the holder of the infringed intellectual property right, which may not be available on reasonable terms or at all; or
- redesign our battery cells at significant expense.

In the event of a successful claim of infringement against us and our failure or inability to obtain a license to continue to use the technology on reasonable terms, our business, prospects, operating results and financial condition could be materially adversely affected. In addition, any litigation or claims, whether or not well-founded, could result in substantial costs, negative publicity, reputational harm and diversion of resources and management's attention.

***Third-party claims or litigation alleging infringement of patents or infringement or misappropriation of other proprietary rights, or seeking to invalidate our patents may adversely affect our business.***

Our success depends in part on our avoiding infringement, misappropriation and other violations of the patents and other intellectual property rights of third parties. Claims of infringement, misappropriation, or other violation of patents or other intellectual property rights are often expensive and time-consuming to defend, and if we were unsuccessful in defense of such claims we could be forced to stop use of certain technologies and/or pay damages or on-going royalties. It is possible that at any time third-parties could attempt to assert an infringement or misappropriation claims if they believe our technology violates their intellectual property rights.

Some of our competitors may have more resources than we do to pursue claims of infringement or misappropriation. We may conclude that even if they are infringing our patents or other intellectual property rights, the risk-adjusted costs of bringing claims against them may be too high or otherwise not in your interest.

***If we are unable to grow, or if we fail to manage future growth effectively, our revenue may not increase and we may be unable to implement our business strategy.***

Our future success depends upon our ability to grow, and if we are unable to manage our growth effectively, we may incur unexpected expenses and be unable to meet our clients' requirements, all of which could materially adversely affect our business, financial condition and results of operations. To manage our current and anticipated future growth effectively, we must continue to maintain and enhance our infrastructure, financial and accounting systems and controls. We must also attract, train and retain a significant number of engineers, sales and marketing personnel, client support personnel, professional services personnel, software engineers, technical personnel and management personnel, and the availability of such personnel may be constrained.

As we continue to grow, including from the integration of employees and businesses acquired in connection with previous or future acquisitions, we may find it difficult to maintain important aspects of our corporate culture, which could negatively affect our profitability and our ability to retain and recruit qualified personnel who are essential for our future success. If we do not effectively manage our growth, we may not be able to execute on our business plan, respond to competitive pressures, take advantage of market opportunities, satisfy client requirements or manufacture high-quality products. Additionally, we may not be able to expand and upgrade our infrastructure to accommodate future growth.

Failure to effectively manage our growth could also lead us to over-invest or under-invest in development and operations; result in weaknesses in our infrastructure, systems or controls; give rise to operational mistakes, financial losses, loss of productivity or business opportunities; and result in loss of employees and reduced productivity of remaining employees. Our growth is expected to require significant capital expenditures and may divert financial resources from other projects such as the development of new products and services. If we are unable to manage our growth effectively, our expenses may increase more than expected, our revenue may not increase or may grow more slowly than expected and we may be unable to implement our business strategy. Further, any failure to manage our growth effectively could materially and adversely affect our business, prospects, operating results and financial condition. We intend to expand our operations significantly which we expect our future expansion to include, among other things:

- expanding the management team;
- hiring and training new personnel;
- leveraging consultants to assist with company growth and development;

- conducting market research and analysis;

## Table of Contents

- controlling expenses and investments in anticipation of expanded operations;
- expanding design, production, and service departments;
- implementing and enhancing administrative infrastructure, systems and processes; and
- expanding our market share in international markets.

***We are subject to requirements relating to environmental and safety regulations and environmental remediation matters which could adversely affect our business, results of operation and reputation.***

Our operations are subject to environmental, health and safety rules laws and regulations laws and regulations including those governing hazardous material handling, transportation, and cleanup and occupational safety and health. There are significant capital, operating and other costs associated with compliance with these environmental laws and regulations. Environmental laws and regulations may become more stringent in the future, which could increase costs of compliance or require us to manufacture with alternative technologies and materials.

We have not yet commenced mass production for our battery products. When mass production is commenced, we will engage OEM suppliers for the manufacturing of our battery products. The manufacturing process will have hazards such as but not limited to hazardous materials, machines with moving parts, and high voltage and/or high current electrical systems typical of large manufacturing equipment and related safety incidents. There may be safety incidents that damage machinery or product, slow or stop production, or harm employees. Consequences may include litigation, regulation, fines, increased insurance premiums, mandates to temporarily halt production, workers' compensation claims, or other actions that impact our company brand, finances, or ability to operate.

While we require that our OEMs and other suppliers have reasonably designed and implemented policies and programs to assure compliance with these laws and regulations and to avoid hazardous substance release liability, there can be no guarantee that the substantial costs incurred by new or more stringent compliance obligations will not be passed on to us.

***Regulatory actions, legal proceedings and customer complaints against us could harm our reputation and have a material adverse effect on our business, results of operations, financial condition and prospects. Our directors, management, shareholders and employees may also from time to time be subject to legal proceedings, which could adversely affect our reputation and results of operations.***

Along with growth and expansion of our business, we may be involved in litigation, regulatory proceedings and other disputes arising in or outside the ordinary course of our business. In general, such litigation and disputes may result in claims for actual damages, freezing of our assets, diversion of our management's attention and reputational damage to us and our management, and the probability and amount of liability, if any, may remain unknown for long periods of time. Given the uncertainty, complexity and scope of many of these litigation matters, their outcome generally cannot be predicted with any reasonable degree of certainty. Therefore, our reserves for such matters may be inadequate. Moreover, even if we eventually prevail in these matters, we could incur significant legal fees or suffer significant reputational harm, which may negatively affect our operating results if changes to our business operations are required. There may also be negative publicity associated with litigation that could decrease consumer acceptance of our product offerings, regardless of whether the allegations are valid or whether we are ultimately found liable. In addition, our directors, management, shareholders and employees may from time to time be subject to litigation, regulatory investigations, proceedings and/or negative publicity or otherwise face potential liability and expense in relation to commercial, labor, employment, securities or other matters, which could adversely affect our reputation and results of operations. As a result, litigation may adversely affect our business, financial condition, results of operations or liquidity.

***We may be subject to declining average selling and leasing prices, which may harm our revenue and gross profits.***

Electric vehicles, light electric vehicles and energy storage systems are subject to declines in average selling and leasing prices due to rapidly evolving technologies, industry standards and consumer preferences. As a result, our clients may expect us as suppliers to cut our costs and lower the price of our products in order to mitigate the negative impact on their own margins.

We expect to face possible market-driven downward pricing pressures in the future. Our revenue and profitability will suffer if we are unable to offset any declines in our average selling or leasing prices by developing new or enhanced products with higher prices or gross profit margins, increasing our sales or leasing volumes or reducing the material costs of our products on a timely basis.

***Our battery products rely on software and hardware that are highly technical, and if these systems contain errors, bugs or vulnerabilities, or if we are unsuccessful in addressing or mitigating technical limitations in our systems, our business could be adversely affected.***

Our products rely on software and hardware, including software and hardware developed or maintained internally or by third parties, that are highly technical and complex and will require modification and updates over the life of a battery product. Certain of

## [Table of Contents](#)

our products depend on the ability of such software and hardware to store, retrieve, process and manage immense amounts of data. Our hardware and software or third party components and software that we utilize in our products may also contain defects in design or manufacture, including “bugs” and other problems that could unexpectedly interfere with the operation or security of the products. In addition, our systems are subject to certain technical limitations that may compromise our ability to meet the objectives. Some errors, bugs or vulnerabilities inherently may be difficult to detect and may only be discovered after the code has been released for external or internal use. Although we attempt to remedy any issues that we observe in our products as effectively and rapidly as possible, such efforts may not be timely, may hamper production, or may not be to the satisfaction of our clients. If we are unable to prevent or effectively remedy errors, bugs, vulnerabilities or defects in our software and hardware, we may suffer damage to our brand, loss of clients, loss of revenue or liability for damages, any of which could adversely affect our business and financial results.

### ***The unavailability, reduction or elimination of government and economic incentives due to policy changes or government regulation could have a material adverse effect on our business, prospects, financial condition and operating results.***

Any reduction, elimination or discriminatory application of government subsidies and economic incentives because of policy changes, the reduced need for such subsidies and incentives due to the perceived success of the electric vehicle industry or other reasons may result in the diminished competitiveness of the alternative fuel and electric vehicle industry generally or our battery power solutions. While certain tax credits and other incentives for alternative energy production, alternative fuel and electric vehicles have been available in the past, there is no guarantee these programs will be available in the future or that they will remain at current levels. In particular, our business will be affected by local and foreign tax credits, rebates, grants and other government programs and incentives that promote the use of electric vehicles. Additionally, our business will be affected by laws, rules and regulations that require reductions in carbon emissions or the use of renewable fuels. These programs and regulations, which have the effect of encouraging the demand for electric vehicles, could expire or be repealed or amended for a variety of reasons. For example, parties with an interest in gasoline and diesel, natural gas or other alternative vehicles or vehicle fuels, including lawmakers, regulators, policymakers, environmental or advocacy organizations, OEMs, trade groups, suppliers or other powerful groups, may invest significant time and money in efforts to delay, repeal or otherwise negatively influence regulations and programs that promote battery powered vehicles. Many of these parties have substantially greater resources and influence than we have. Further, changes in local or foreign political, social or economic conditions, including a lack of legislative focus on these programs and regulations, could result in their modification, delayed adoption or repeal. Any failure to adopt, delay in implementation, expiration, repeal or modification of these programs and regulations, or the adoption of any programs or regulations that encourage the use of other alternative fuels or alternative vehicles over battery power, would reduce the market for batteries as a source of power and harm our operating results, liquidity and financial condition.

### ***We will face risks associated with potential international operations, including unfavorable local regulatory, political, tax and labor conditions, which could harm our business.***

We will face risks associated with any potential international operations, including possible unfavorable local regulatory, political, tax and labor conditions, which could harm our business. We anticipate having subsidiaries that are subject to the legal, political, regulatory and social requirements and economic conditions in international jurisdictions. We may be subject to a number of risks associated with international business activities that may increase our costs, impact our ability to manufacture, sell or lease our products and require significant management attention. These risks include, but are not limited to:

- conforming our products to various international regulatory requirements where those products are sold or leased, which requirements may change over time;
- local and foreign government trade restrictions, tariffs and price or exchange controls;
- changes in diplomatic and trade relationships;
- political instability, civil disturbances, war, military conflict, religious or ethnic strife, terrorism and general security concerns;
- the occurrence of severe health epidemics, pandemics or other disease outbreaks; and
- the strength of international economies.

If we fail to address these risks successfully, our business and prospects could be negatively impacted.

### ***Our operations and investments are located in Asia-Pacific and we are therefore exposed to various risks inherent in operating and investing in the region.***

We will be focusing primarily on the Asia-Pacific market, including but not limited to Singapore, Thailand, the Philippines, Indonesia, India, Australia, and PNG, which means that other than assets located in and most of the income derived from our Singapore and Australia business, our assets and income are located in emerging market countries. Emerging market countries are typically subject to greater political, policy, legal, economic, taxation and other risks and uncertainties, including but not limited to the

risk of expropriation, nationalization and commercial or governmental disputes, inflation, interest rate and currency fluctuations and greater difficulty in enforcing or collecting payment against contracts or in having certainty that all required governmental and

## [Table of Contents](#)

regulatory approvals necessary to run our business are in place and will be renewed. Asian markets are inherently non-homogenous and require bespoke business models for each country in which we operate which adds complexity and reduces economies of scale.

Emerging market countries where we operate may have less sophisticated legal, taxation and regulatory systems and frameworks, including but not limited to unexpected changes in, or inconsistent application, interpretation or enforcement of, applicable laws and regulatory requirements. In particular, because legislation and other laws and regulations in emerging markets are often undeveloped, it is frequently difficult to interpret those laws and regulations with certainty. Regulatory authorities may adopt different interpretations to us or may revise laws, regulations or interpretations, potentially with retrospective effect, in ways that adversely affect our business, financial condition and/or results of operations. This gives rise to increased risks relating to labor practices, foreign ownership restrictions, tax regulation and enforcement, difficulty in enforcing contracts, changes to or uncertainty in the relevant legal and regulatory regimes and other issues in the markets where we operate or may in the future operate. Such risks could interrupt or adversely impact some or all of our business and may adversely affect our business, financial condition and results of operations.

Most of the countries we will be focusing on have experienced political and social instability at various times in the past, including but not limited to acts of political violence and civil unrest. These countries also have been subject to a number of terrorist attacks and other destabilizing events, which have led to economic and social volatility. There can be no assurance that similar destabilizing events will not occur in the future. Any such destabilizing events could interrupt and adversely affect our business, financial condition and results of operations.

Investors should also note that emerging markets are also subject to rapid change. An increase in the perceived risks associated with investing in emerging economies could reduce foreign investment in these countries, which may have a materially adverse impact on the battery markets in those places, or make it more difficult for us to obtain debt and equity financing, which could adversely affect our financial capacity to meet our business objectives and therefore adversely affect our business, financial condition and results of operations.

### ***Fluctuations in foreign currency exchange rates will affect our financial results, which we report in U.S. Dollars.***

We plan to operate in multiple jurisdictions, which exposes us to the effects of fluctuations in currency exchange rates. We may earn revenue in Singaporean Dollars, Australia Dollars, Thai Baht, Indonesian Rupiah, Indian Rupee, Philippine Peso and PNG Kina among other currencies. Our consolidated financial statements are presented in U.S. Dollars, which is the functional currency of noco-noco. Fluctuations in the exchange rates between the various currencies that we use could result in expenses being higher and revenue being lower than would be the case if exchange rates were stable. We cannot assure you that movements in foreign currency exchange rates will not have a material adverse effect on our results of operations in future periods. Furthermore, a substantial amount of our revenue is denominated in emerging markets currencies. Because fluctuations in the value of emerging markets currencies are not necessarily correlated, there can be no assurance that our results of operations will not be adversely affected by such volatility.

### ***Changes in public policies affecting the development and more widespread adoption of electric vehicles could affect the demand for our products.***

We mainly offer leasing services of our battery products, including batteries, BEVs and ESS, and manage carbon abatement projects and sell carbon credits to commercial transportation companies, renewable energy plants and power plants. If the market for electric vehicles or renewable energy does not develop, demand for our products or services could be harmed. As a result, our success depends, in part, on laws that affect demand for electric vehicles. For example, laws compelling the reduction of greenhouse gas emissions could create opportunity for increased sales of our batteries for incorporation in BEVs. Incentives, including tax credits or rebates, for electric vehicle purchases to reduce greenhouse gas emissions create a climate in which our sales may increase. Eliminating or phasing out such incentives could have the opposite effect. The continuous generation of carbon credits is an essential component to offset the unavoidable emissions in our leasing business. Our financial success may depend, in part, on our ability to generate tradable regulatory emission credits and provide carbon offset solutions to our clients. Laws that restrict or diminish the value of such credits may lessen our electric vehicle producing clients' demand for our batteries.

### ***Our carbon abatement solutions business may be impacted by climate-related activities.***

Our carbon abatement solutions business may be impacted by certain climate-related activities, including:

- technological advancements in the carbon reduction/removal process to mitigate climate change;
- domestic and international regulatory compliance response to climate change, or imposition of any specific taxation, penalties or fines, and
- unpredictable and extreme weather patterns and events which may extend to a long-term shift in climate weather patterns.

Given our carbon abatement solutions business are largely exposed to climate-related activities, any unfavorable changes will have an adverse impact on us, and may further impact the ongoing viability of our carbon abatement projects.



## [Table of Contents](#)

***Our business depends substantially on the continuing efforts of our senior management team and the loss of one or more of these employees could adversely affect our business.***

Our success depends largely upon the continued services of our key executive officers. We also rely on our management team in the areas of research and development, marketing, services and general administrative functions. If one or more of our other senior executives are unable or unwilling to continue to work for us in their present positions, we would be significantly disadvantaged. Moreover, if any of our current or former senior executives joins a competitor or forms a competing company, we may lose clients, suppliers, know-how and key personnel. Each of our executive officers has entered into an employment agreement with us, which contains confidentiality clauses.

Our success also depends, in part, on our continuing ability to identify, hire, attract, train and develop other highly qualified personnel, in particular engineers specializing in various disciplines, including battery design and production. Experienced and highly skilled employees are in high demand and competition for these employees can be intense. Our ability to hire, attract and retain them depends on our ability to provide competitive compensation packages. We may not be able to attract, integrate, train, motivate or retain additional highly qualified personnel, and our failure to do so could adversely affect our business, prospects, financial condition and operating results.

The unexpected loss of or failure to retain one or more of our key employees could adversely affect our business. We do not currently maintain key man life insurance policies with respect to every officer and will evaluate whether to obtain such additional key man life insurance policies. Any failure by our management team and our employees to perform as expected may have a material adverse effect on our business, prospects, financial condition and operating results.

***Any failure to offer high-quality maintenance services may adversely affect our relationships with our clients and harm our financial results.***

We are highly dependent on the quality of our products, our business reputation and on strong recommendations from our existing clients. Any failure to maintain high-quality maintenance services, or a market perception that we do not maintain high-quality maintenance, could harm our reputation, adversely affect our ability to lease our products to existing and prospective clients, and harm our business, operating results and financial condition.

We provide maintenance services with the batteries, BEVs and ESS when we lease to our clients and may be unable to respond quickly enough to accommodate short-term increases in demand for maintenance services, particularly as we increase the size of our client base. Additionally, increased demand for these services, without corresponding revenue, could increase costs and adversely affect our results of operations.

***Our management has limited experience in operating a public company.***

Our executive officers have limited experience in the management of a publicly traded company. Our management team may not successfully or effectively manage our transition to a public company that will be subject to significant regulatory oversight and reporting obligations under federal securities laws. Their limited experience in dealing with the increasingly complex laws pertaining to public companies could be a significant disadvantage in that it is likely that an increasing amount of their time may be devoted to these activities which will result in less time being devoted to the management and growth of us. We may not have adequate personnel with the appropriate level of knowledge, experience, and training in the accounting policies, practices or internal controls over financial reporting required of public companies in the United States. The development and implementation of the standards and controls necessary for us to achieve the level of accounting standards required of a public company in the United States may require costs greater than expected. It is possible that we will be required to expand its employee base and hire additional employees to support its operations as a public company which will increase its operating costs in future periods.

***We have identified material weakness in our internal control over financial reporting. Our failure to maintain an effective system of internal control over financial reporting may result in material misstatements of our consolidated financial statements or cause us to fail to meet our periodic reporting obligations, which may adversely affect investor confidence in us and, as a result, the value of our shares.***

Our management has concluded that, as of June 30, 2023, our existing disclosure controls and procedures and internal control over financial reporting were ineffective, due to a material weakness. The material weakness relates to lack of sufficient financial reporting and accounting personnel, especially those with U.S. GAAP knowledge. Moreover, even if our management may in the future conclude that our internal control over financial reporting is effective, our independent registered public accounting firm, after conducting its own independent testing, may issue a report that is qualified if it concludes that we have not maintained, in all material respects, effective internal control over financial reporting based on criteria established in Internal Control — Integrated Framework (2013) issued by the Committee of Sponsoring Organizations of the Treadway Commission (COSO). During the course of

documenting and testing our internal control procedures, in order to satisfy the requirements of Section 404 of the Sarbanes-Oxley Act of 2002, we may identify other weaknesses and deficiencies in our internal control over financial reporting. If we fail to maintain the adequacy of our internal control over financial reporting, we may not be able to conclude on an ongoing basis that we have

## [Table of Contents](#)

effective internal control over financial reporting in accordance with Section 404 of the Sarbanes-Oxley Act of 2002. If we fail to achieve and maintain an effective internal control environment, we could suffer material misstatements in our financial statements and fail to meet our reporting obligations, which would likely cause investors to lose confidence in our reported financial information. This could in turn limit our access to capital markets, harm our results of operations, and lead to a decline in the trading price of our ordinary shares. Additionally, ineffective internal control over financial reporting could expose us to increased risk of fraud or misuse of corporate assets and subject us to potential delisting from the stock exchange on which we list, regulatory investigations and civil or criminal sanctions.

As we became a public company following the consummation of the Business Combination, our reporting obligations may place a significant strain on our management, operational and financial resources and systems for the foreseeable future. Section 404 of the Sarbanes-Oxley Act requires that we include a report from management on the effectiveness of our internal control over financial reporting in our annual report on Form 20-F beginning with its second annual report on Form 20-F after becoming a public company. In addition, once we cease to be an “emerging growth company” as such term is defined in the JOBS Act, our independent registered public accounting firm may need to attest to and report on the effectiveness of our internal control over financial reporting. We may be unable to timely complete our evaluation testing and any required remediation. In addition, because we will be an “emerging growth company” and intend to take advantage of exemptions from various reporting requirements that are applicable to most other public companies, including, but not limited to, an exemption from the provisions of Section 404(b) of the Sarbanes-Oxley Act requiring that our independent registered public accounting firm provide an attestation report on the effectiveness of its internal control over financial reporting, any remedial measures that we take to remedy material weakness and control deficiencies may not be independently verified by an independent third party. To remediate our identified material weakness and improve our internal control over financial reporting, we are in the process of implementing a number of measures to address the identified material weakness, including:

(i) establishing clear roles and responsibilities for accounting and financial reporting staff to address accounting and financial reporting issues, and adding additional professionals for our financial reporting team; (ii) implementing regular and continuous U.S. GAAP accounting and financial reporting training programs for our accounting and financial reporting personnel; and (iii) strengthening corporate governance.

The growth and expansion of our business may place a significant strain on our operational and financial resources in the future. As we continue to grow, we may not be able to successfully implement requisite improvements to our internal control systems, controls and processes, such as system access and change management controls, in a timely or efficient manner. Our failure to improve our systems and processes, or their failure to operate in the intended manner, whether as a result of the growth of our business or otherwise, may result in our inability to accurately forecast our revenue and expenses, or to prevent certain losses. Moreover, the failure of our systems and processes could undermine our ability to provide accurate, timely and reliable reports on our financial and operating results and could impact the effectiveness of our internal control over financial reporting.

***We may need to raise additional funds and these funds may not be available to us when we need them. If we cannot raise additional funds when we need them, our business, prospects, financial condition and operating results could be negatively affected.***

The design, manufacture, sale and servicing of our battery products are capital-intensive. We expect that following the consummation of the Business Combination, we will have sufficient capital to fund our planned operations for the next three years, at which point we expect to be generating self-sustaining free cash flow. However, we may need to raise additional capital to scale our operations, continue licensing in intellectual properties and technologies and expand into emerging markets. Further, we may subsequently determine that additional funds are necessary earlier than anticipated. We may raise additional funds through the issuance of equity, equity related or debt securities, or through obtaining credit from government or financial institutions. This capital may be necessary to fund our ongoing operations, continue improving our technologies, and development and design efforts. We cannot be certain that additional funds will be available to us on favorable terms when required, or at all. If we cannot raise additional funds when we need them, our financial condition, results of operations, business and prospects could be materially adversely affected.

***The consolidated financial statements accompanying this Report contain disclosures related to our ability to continue as a going concern.***

The consolidated financial statements included in this Report were prepared on a going concern basis, which assumes that assets are realized and liabilities are extinguished in the ordinary course of business at the amounts as disclosed in the financial statements. As of June 30, 2023 and 2022, we had an accumulated deficit of \$19,143,513 and \$2,351,743 respectively. We incurred net loss of \$16,791,770 and \$1,076,823 for the financial years ended June 30, 2023 and 2022, respectively. The cash used in operating activities for the financial year ended June 30, 2023 and 2022, was \$2,982,778 and \$805,177, respectively. These conditions raise substantial doubt about our ability to continue as a going concern.

Our ability to continue as a going concern is dependent on our management's ability to successfully execute our business plan, which includes increasing revenue while controlling operating cost and expenses to generate positive operating cash flows and obtaining funds from outside sources of financing to generate positive financing cash flows. Management has commenced a strategy

## [Table of Contents](#)

to raise debt and equity. To sustain our ability to support our operating activities, we have considered supplementing our sources of funding through the following: (i) additional financial support from our related parties and shareholders; (ii) raising funds through private placement of shares to new strategic investors; and (iii) other available sources of financing from banks and other financial institutions.

There is no assurance that the plans will be successfully implemented. If we fail to achieve these goals, we may need additional financing to repay debt obligations and execute our business plan, and we may not be able to obtain the necessary additional capital on a timely basis, on acceptable terms, or at all. In the event that financing sources are not available, or that we are unsuccessful in increasing our gross profit margin and reducing operating losses, we may be unable to implement our current plans for expansion, repay debt obligations or respond to competitive pressures, any of which would have a material adverse effect on our business, financial condition and results of operations and may materially adversely affect its ability to continue as a going concern.

Our independent registered public accounting firm included an explanatory paragraph about our ability to continue as a going concern in its report on our consolidated financial statements for the year ended June 30, 2023. The inclusion of a going concern explanatory paragraph may negatively impact the trading price of our Ordinary Shares, have an adverse impact on our relationship with third parties with whom we do business, including our customers, vendors and employees, and could make it challenging and difficult for us to raise additional debt or equity financing to the extent needed, all of which could have a material adverse impact on our business, results of operations, financial condition and prospects.

For additional information on the above-referenced accounting standards and matters affecting our ability to continue as a going concern, see Note 2 to the financial statements included in this report and the discussion included in “Item 5. Operating and Financial Review and Prospects--B. Liquidity and Capital Resources.”

### ***We rely on information technology and any failure, inadequacy, interruption or security lapse of that technology, including any cybersecurity incidents, could harm our ability to operate our business effectively.***

Experienced computer programmers and hackers may be able to penetrate our network and misappropriate or compromise our confidential information or that of third parties, create system disruptions or cause shutdowns. Computer programmers and hackers also may be able to develop and deploy viruses, worms and other malicious software programs that attack our products or otherwise exploit any security vulnerabilities of our products. While we employ a number of protective measures, including firewalls, network infrastructure vulnerability scanning, anti-virus and endpoint detection and response technologies, these measures may fail to prevent or detect attacks on our systems which could adversely affect our business, operations, or products.

Any claim that our products or systems are subject to a cybersecurity risk, whether valid or not, could damage our reputation and adversely impact our revenues and results of operations. We manage and store various proprietary information and sensitive or confidential data relating to our business, which in the future may as well contain information from our suppliers and clients. Breaches of our or any of our third party suppliers’ security measures or the accidental loss, inadvertent disclosure or unapproved dissemination of proprietary information or sensitive or confidential data about us or our clients or suppliers, including the potential loss or disclosure of such information or data as a result of fraud, trickery or other forms of deception, could expose us or our clients or suppliers to a risk of loss or misuse of this information, result in litigation and potential liability for us, damage our brand and reputation or otherwise harm our business.

To the extent we experience cyber-security incidents in the future, our relationships with our clients and suppliers may be materially impacted, our brand and reputation may be harmed and we could incur substantial costs in responding to and remediating the incidents and in resolving any investigations or disputes that may arise with respect to them, any of which would cause our business, operations, or products to be adversely affected. In addition, the cost and operational consequences of implementing and adding further data protection measures could be significant.

### ***We may in the future be, adversely affected by the global COVID-19 pandemic or other similar outbreaks.***

We face various risks related to epidemics, pandemics, and other outbreaks, including the recent COVID-19 pandemic. The impact of COVID-19, including changes in consumer and business behavior, pandemic fears and market downturns, and restrictions on business and individual activities, has created significant volatility in the global economy and led to reduced economic activity. The spread of COVID-19 may impact our potential clients and suppliers by disrupting the manufacturing, delivery and overall supply chain of battery and BEV manufacturers and suppliers and may lead to a global decrease in battery and BEV sales or leasing in markets around the world.

The pandemic has resulted in government authorities implementing numerous measures to try to contain the virus, such as travel bans and restrictions, quarantines, stay-at-home or shelter-in-place orders, and business shutdowns. Although we had not experienced any impact from the pandemic, these measures still may adversely impact our employees, research and development activities and operations and the operations of our suppliers, vendors and business partners, and may negatively impact our sales and marketing activities in the future. In addition, various aspects of our business cannot be conducted remotely. These measures by government

authorities may remain in place for a significant period of time and they are likely to continue to adversely affect our future manufacturing plans, sales and marketing activities, business and results of operations. We may take actions as may be required by government authorities or that it determines are in the best interests of its employees, suppliers, vendors and business partners.

## [Table of Contents](#)

The extent to which the COVID-19 pandemic may impact our business, prospects and results of operations will depend on future developments, which are highly uncertain and cannot be predicted, including the duration and spread of the pandemic, its severity, the actions to contain the virus or treat its impact, and how quickly and to what extent normal economic and operating activities can resume. Even after the COVID-19 pandemic has subsided, we may experience an adverse impact to its business as a result of its global economic impact, including any recession that has occurred or may occur in the future.

There are no comparable recent events that may provide guidance as to the effect of the spread of COVID-19 and a pandemic, and, as a result, the ultimate impact of the COVID-19 pandemic or a similar health epidemic is highly uncertain.

The future impact of the COVID-19 outbreak is highly uncertain and cannot be predicted and there is no assurance that such outbreak will not have a material adverse impact on our business, financial condition and results of operations. The extent of the impact will depend on future developments, including actions taken to contain COVID-19, and if these impacts persist or exacerbate over an extended period of time.

### ***Our business activities in the Oceanian countries may be subject to native title and/or indigenous cultural heritage rights.***

Native title and/or indigenous cultural heritage rights may impact our ability to obtain landowner agreements, permits and approvals. In Australia, the Native Title Act 1993 (Cth) recognizes rights of indigenous Australians over land, and such recognition may impact or delay our ability to carry out our business activities, either wholly or partially. There are also Australian state and territory legislations which impose duties of care on us to ensure all practical and reasonable measures are taken to avoid damaging or destroying indigenous cultural heritage. These laws and regulations are subject to constant review and amendments. If we are unable to obtain consent from indigenous persons to the potential target areas of a planned carbon abatement project, that particular project would have to be abandoned, which will adversely affect our business and financial performance.

In addition, our business activities may be subject to the First Nations and/or indigenous persons claims. To carry out our business activities, consultation and discussions with the First Nations and/or other indigenous groups will be required from time to time. Any unsuccessful consultation or discussions will impact our ability to perform our business activities. In the event the land underlying a carbon abatement project is determined to be native title, we will need to appropriately amend our internal policies and procedures to ensure compliance, which may delay our project timeline and adversely affect our business. In addition, we may at times be restricted, either legally or culturally, from the properties or lands due to sociological issues, which may also adversely affect our business.

### ***We may be subject to government policy changes under the federal political system of Australia.***

Australia has consistently operated under a mild two-party federal political system, with two major party alliances dominating the political groupings in the Australian system. The carbon abatement projects, although having experienced prolonged periods of continuance between both party alliances, may be revoked upon a change in the federal system to be realigned with the incumbent political party's policies. Any change in government policies, legislation or regulation that affect carbon abatement projects may directly impact our business operations. Generally, the state-based political parties in Australia also follow a mild two-party system, which may present conflicts between state policies and federal policies, in turn creating uncertainty and volatility for our operations.

In addition, there may be changes in taxation, interest rates and other administrative functions of both the state and federal governing laws and regulations which may have an adverse impact on our assets, operations and financial performance. Changes to existing laws and regulations governing the carbon abatement projects may also require us to implement such changes, which may adversely impact both current and any future projects.

### ***Uncertainties with respect to laws and regulations in the countries in which we operate could adversely affect our business, financial condition and results of operations.***

Our business is subject to a range of regulations, including but not limited to safety, environmental, tax, anti-money laundering, countering of terrorism financing and competition legislation in different jurisdictions. Governments and regulatory authorities in the countries where we operate may from time to time make changes to applicable laws and regulatory policies, which may make it more difficult or onerous for us to operate. Additionally, laws and policies in emerging markets may change at short notice and may subject us to additional penalties.

In addition, any interpretation of laws and practice by the governments and/or regulatory authorities that is contrary to our views of those laws and practice may adversely affect our liabilities or expose us to legal, regulatory or other actions. Inconsistent enforcement of laws also creates compliance risks, as it may make it difficult for us to engage with regulatory authorities on compliance matters. Such inconsistency may also result in variability in the penalties associated with any non-compliance. Appeals

against the enforcement actions taken by regulatory authorities may not always be possible, and it may take a long time to reach conclusion, may incur significant costs and the results may be uncertain and involve external influences outside our control.



## [Table of Contents](#)

### **Risks Related to Ownership of Our Securities**

#### ***The market price and trading volume of our Securities may be volatile and could decline significantly.***

The stock markets, including the Nasdaq on which we listed our Ordinary Shares and Warrants (collectively, “Securities”), have from time to time experienced significant price and volume fluctuations. Even if an active, liquid and orderly trading market develops and is sustained for our Securities, the market prices of our Securities may be volatile and could decline significantly. In addition, the trading volumes in our Securities may fluctuate and cause significant price variations to occur. If the market prices of our Securities decline significantly, you may be unable to resell our Securities you held at or above the market price of the our Securities as of the date immediately following the consummation of the Business Combination. There can be no assurance that the market prices of our Securities will not fluctuate widely or decline significantly in the future in response to a number of factors, including, among others, the following:

- the realization of any of the risk factors presented in this Report
- actual or anticipated differences in our estimates, or in the estimates of analysts, for our revenues, results of operations, cash flows, level of indebtedness, liquidity or financial condition;
- announcements by us or our competitors of significant business developments;
- changes in clients;
- acquisitions or expansion plans;
- our involvement in litigation;
- sale of our Ordinary Shares or Warrants or other securities in the future;
- market conditions in our industry;
- changes in key personnel;
- the trading volume of our Securities;
- actual, potential or perceived control, accounting or reporting problems;
- changes in accounting principles, policies and guidelines;
- other events or factors, including but not limited to those resulting from infectious diseases, health epidemics and pandemics (including but not limited to the ongoing COVID-19 pandemic), natural disasters, war, acts of terrorism or responses to these events; and
- general economic and market conditions.

In addition, the stock markets have experienced extreme price and volume fluctuations. Broad market and industry factors may materially harm the market price of our Securities, regardless of our operating performance. In the past, following periods of volatility in the market price of a company’s securities, securities class action litigation has often been instituted against that company. If we were involved in any similar litigation, it could incur substantial costs and our management’s attention and resources could be diverted.

#### ***We may issue additional Ordinary Shares or other equity or convertible debt securities without approval of the holders of our Securities, which would dilute existing ownership interests and may depress the market price of our Securities.***

We may continue to require capital investment to support its business, and we may issue additional Ordinary Shares or other equity or convertible debt securities of equal or senior rank in the future without approval of the holders of our Securities in certain circumstances.

Our issuance of additional Ordinary Shares or other equity or convertible debt securities would have the following effects: (i) Our existing shareholders’ proportionate ownership interest in us may decrease; (ii) the amount of cash available per share, including for payment of dividends in the future, may decrease; (iii) the relative voting power of each previously outstanding Ordinary Share may be diminished; and (iv) the market price of our Securities may decline.

Furthermore, our employees, directors or consultants are expected to be granted equity awards under the PubCo Incentive Plan, subject to a limit of 5% of the fully diluted share capital that is issued and outstanding upon consummation of the Business Combination, in the first year of issue. You will experience additional dilution when those equity awards and purchase rights become vested and settled or exercised, as applicable, for our Ordinary Shares.

*If securities or industry analysts do not publish research, publish inaccurate or unfavorable research or cease publishing research about us, the market price and trading volume of our Securities could decline significantly.*

## [Table of Contents](#)

The trading market for our Securities will depend, in part, on the research and reports that securities or industry analysts publish about us or our business. We may be unable to sustain coverage by well-regarded securities and industry analysts. If either none or only a limited number of securities or industry analysts maintain coverage of us, or if these securities or industry analysts are not widely respected within the general investment community, the demand for our Securities could decrease, which might cause the market prices and trading volumes of our Securities to decline significantly. In the event that we obtain securities or industry analyst coverage, if one or more of the analysts who cover us downgrade their assessment of us or publish inaccurate or unfavorable research about our business, the market price and liquidity of our Securities could be negatively impacted.

***The requirements of being a public company may strain our resources, divert our management's attention and affect our ability to attract and retain qualified board members.***

We are subject to the reporting requirements of the Exchange Act, the Sarbanes-Oxley Act, the Dodd-Frank Act, the Nasdaq listing requirements and other applicable securities rules and regulations. These expenses may increase even more if we no longer qualify as an "emerging growth company," as defined in Section 2(a) of the Securities Act. The Exchange Act requires, among other things, that we file annual and current reports with respect to its business and operating results. The Sarbanes-Oxley Act requires, among other things, that we maintain effective disclosure controls and procedures and internal control over financial reporting. We may need to hire more employees or engage outside consultants to comply with these requirements, which will increase our costs and expenses.

Changing laws, regulations and standards relating to corporate governance and public disclosure are creating uncertainty for public companies, increasing legal and financial compliance costs and making some activities more time-consuming. These laws, regulations and standards are subject to varying interpretations, in many cases due to their lack of specificity, and, as a result, their application in practice may evolve over time as new guidance is provided by regulatory and governing bodies. This could result in continuing uncertainty regarding compliance matters and higher costs necessitated by ongoing revisions to disclosure and governance practices. We expect these laws and regulations to increase our legal and financial compliance costs and to render some activities more time-consuming and costly, although we are currently unable to estimate these costs with any degree of certainty.

Our management team has limited experience managing a publicly traded company, interacting with public company investors and complying with the increasingly complex laws pertaining to public companies. Our management team may not successfully or efficiently manage the transition to being a public company subject to significant regulatory oversight and reporting obligations under the federal securities laws and regulations and the continuous scrutiny of securities analysts and investors. The need to establish the corporate infrastructure demanded of a public company may divert the management's attention from implementing its growth strategy, which could prevent us from improving our business, financial condition and results of operations. Furthermore, we expect these rules and regulations to make it more difficult and more expensive for us to obtain director and officer liability insurance, and consequently we may be required to incur substantial costs to obtain such coverage. These additional obligations could have a material adverse effect on our business, financial condition, results of operations and prospects.

These factors could also make it more difficult for us to attract and retain qualified members of its board of directors, particularly to serve on our audit and risk committee, remuneration committee and nominating committee, and qualified executive officers.

As a result of disclosure of information in this Report and in filings required of a public company, our business and financial condition will become more visible, which may result in threatened or actual litigation, including by competitors and other third parties. If such claims are successful, our business and operating results could be adversely affected, and, even if the claims do not result in litigation or are resolved in our favor, these claims, and the time and resources necessary to resolve them, could have an adverse effect on our business, financial condition, results of operations and prospects.

***We are an "emerging growth company" and it cannot be certain if the reduced SEC reporting requirements applicable to emerging growth companies will make our Securities less attractive to investors, which could have a material and adverse effect on us, including our growth prospects.***

We are an "emerging growth company" as defined in the JOBS Act and will remain an "emerging growth company" until the earliest to occur of (i) the last day of the fiscal year (a) following the fifth anniversary of the closing of the Business Combination, (b) in which we have total annual gross revenue of at least \$1.235 billion or (c) in which we are deemed to be a large accelerated filer, which means the market value of our Securities held by non-affiliates exceeds \$700 million as of the last business day of our prior second fiscal quarter, and (ii) the date on which we issued more than \$1.0 billion in non-convertible debt during the prior three-year period. We intend to take advantage of exemptions from various reporting requirements that are applicable to most other public companies, whether or not they are classified as "emerging growth companies," including, but not limited to, an exemption from the provisions of Section 404(b) of the Sarbanes-Oxley Act requiring that our independent registered public accounting firm provide an attestation report on the effectiveness of our internal control over financial reporting and reduced disclosure obligations regarding

executive compensation, and exemptions from the requirements of holding a non-binding advisory vote on executive compensation and shareholder approval of any golden parachute payments not previously approved.

## [Table of Contents](#)

Furthermore, even after we no longer qualifies as an “emerging growth company,” as long as we continue to qualify as a foreign private issuer under the Exchange Act, we will be exempt from certain provisions of the Exchange Act that are applicable to U.S. domestic public companies, including, but not limited to, the sections of the Exchange Act regulating the solicitation of proxies, consents or authorizations in respect of a security registered under the Exchange Act; the sections of the Exchange Act requiring insiders to file public reports of their stock ownership and trading activities and liability for insiders who profit from trades made in a short period of time; and the rules under the Exchange Act requiring the filing with the SEC of quarterly reports on Form 10-Q containing unaudited financial and other specified information, and current reports on Form 8-K, upon the occurrence of specified significant events. In addition, we will not be required to file annual reports and financial statements with the SEC as promptly as U.S. domestic companies whose securities are registered under the Exchange Act, and are not required to comply with Regulation FD, which restricts the selective disclosure of material information.

As a result, our shareholders may not have access to certain information they deem important. We cannot predict if investors will find our Securities less attractive because it relies on these exemptions. If some investors do find our Securities less attractive as a result, there may be a less active trading market and the market price of our Securities may be more volatile.

***We are a company incorporated in the Cayman Islands and have qualified as a foreign private issuer within the meaning of the rules under the Exchange Act, and as such we are exempt from certain provisions applicable to United States domestic public companies.***

We are a foreign private issuer as such term is defined in Rule 405 under the Securities Act and are a company incorporated in the Cayman Islands, and, we are a listed company on the Nasdaq. The Nasdaq market rules permit a foreign private issuer like us to follow the corporate governance practices of its home country. Certain corporate governance practices in the Cayman Islands, which is our home country, may differ significantly from the Nasdaq corporate governance listing standards applicable to domestic U.S. companies.

Because we have qualified as a foreign private issuer under the Exchange Act immediately following the consummation of the Business Combination, we are exempt from certain provisions of the securities rules and regulations in the United States that are applicable to U.S. domestic issuers, including: (i) the rules under the Exchange Act requiring the filing of quarterly reports on Form 10-Q and current reports on Form 8-K with the SEC; (ii) the sections of the Exchange Act regulating the solicitation of proxies, consents, or authorizations in respect of a security registered under the Exchange Act; (iii) the sections of the Exchange Act requiring insiders to file public reports of their share ownership and trading activities and liability for insiders who profit from trades made in a short period of time; and (iv) the selective disclosure rules by issuers of material nonpublic information under Regulation FD.

In addition, we are not required to have: (i) a majority of the board of directors consist of independent directors; (ii) a compensation committee consisting of independent directors; (iii) a nominating and corporate committee consisting of independent directors; or (iv) regularly scheduled executive sessions with only independent directors each year.

We intend to rely on some of the exemptions listed above. As a result, you may not be provided with the benefits of certain corporate governance requirements of the Nasdaq applicable to U.S. domestic public companies.

We are required to file an annual report on Form 20-F within four months of the end of each fiscal year. Press releases relating to financial results and material events will also be furnished to the SEC on Form 6-K. However, the information we are required to file with or furnish to the SEC will be less extensive and less timely compared to that required to be filed with the SEC by U.S. domestic issuers. Accordingly, you may receive less or different information about us than you would receive about a U.S. domestic public company.

The determination of foreign private issuer status is made annually on the last business day of an issuer’s most recently completed second fiscal quarter. In the future, we could lose our status as a foreign private issuer under current SEC rules and regulations if more than 50% of our outstanding voting securities become directly or indirectly held of record by U.S. holders and any one of the following is true: (i) the majority of our directors or executive officers are U.S. citizens or residents; (ii) more than 50% of our assets are located in the United States; or (iii) our business is administered principally in the United States. If we lose our status as a foreign private issuer in the future, it will no longer be exempt from the rules described above and, among other things, will be required to file periodic reports and annual and quarterly financial statements as if we were a company incorporated in the United States. If this were to happen, we would likely incur substantial costs in fulfilling these additional regulatory requirements, including costs related to the preparation of financial statements in accordance with U.S. GAAP, and members of our management would likely have to divert time and resources from other responsibilities to ensuring these additional regulatory requirements are fulfilled.

***Because we are a “controlled company” as defined in the Nasdaq Stock Market Rules, you may not have protections of certain corporate governance requirements which otherwise are required by Nasdaq’s rules.***

Under Nasdaq's rules, a controlled company is a company of which more than 50% of the voting power for the election of directors is held by an individual, group or another company. We are a controlled company because 3DOM Alliance, our parent company, holds more than 50% of our voting power. For so long as we remain a controlled company, we are not required to comply

## [Table of Contents](#)

with the following permitted to elect to rely, and may rely, on certain exemptions from the obligation to comply with certain corporate governance requirements, including:

- our board of directors is not required to be comprised of a majority of independent directors.
- our board of directors is not subject to the compensation committee requirement; and
- we are not subject to the requirements that director nominees be selected either by the independent directors or a nomination committee comprised solely of independent directors.

As a result, if we take advantage of these exemptions, you will not have the same protections afforded to shareholders of companies that are subject to all of the Nasdaq corporate governance requirements. We intend to take advantage some of these controlled company exemptions. As a result, you may not be provided with the benefits of certain corporate governance requirements of Nasdaq applicable to U.S. domestic public companies.

***You may face difficulties in protecting your interests, and certain judgement obtained against our directors and officers may not be enforceable.***

We are an exempted company limited by shares incorporated under the laws of the Cayman Islands, and we conduct a majority of its operations through our subsidiary, noco-noco Pte. Ltd, outside the United States. Substantially all of our assets are located outside the United States. All of our current officers and directors are nationals and residents of countries other than the United States and a substantial portion of the assets of those persons are located outside of the United States. As a result, it could be difficult or impossible for you to bring an action against us or against these individuals outside of the United States in the event that you believe that your rights have been infringed upon under the applicable securities laws or otherwise and it will be difficult to effect service of process within the United States upon our officers or directors, or enforce judgments obtained in United States courts against our officers or directors. Even if you are successful in bringing an action of this kind, the laws of the Cayman Islands and of the jurisdictions that comprise the Asian region could render you unable to enforce a judgment against our assets or the assets of our directors and officers. In addition, it is unclear if any applicable extradition treaties now in effect between the United States and Asia markets would permit effective enforcement of criminal penalties of U.S. federal securities laws.

In addition, our corporate affairs are governed by our amended and restated memorandum and articles of association (“***Amended and Restated Memorandum and Articles of Association***”), the Cayman Islands Companies Act and the common law of the Cayman Islands. The rights of shareholders to take action against the directors, actions by minority shareholders and the fiduciary duties of our directors to our Company under Cayman Islands law are to a large extent governed by the common law of the Cayman Islands. The common law of the Cayman Islands is derived in part from comparatively limited judicial precedent in the Cayman Islands as well as from the common law of England and Wales, the decisions of whose courts are of persuasive authority, but are not binding, on a court in the Cayman Islands. The rights of our shareholders and the fiduciary duties of our directors under Cayman Islands law may not be as clearly established as they would be under statutes or judicial precedent in some jurisdictions in the United States. In particular, the Cayman Islands has a different body of securities laws than the United States. Some U.S. states, such as Delaware, may have more fully developed and judicially interpreted bodies of corporate law than the Cayman Islands. In addition, Cayman Islands companies may not have standing to initiate a shareholder derivative action in a federal court of the United States.

Shareholders of Cayman Islands exempted companies like us have no general rights under Cayman Islands law to inspect corporate records (other than the memorandum and articles of association, any special resolutions passed by such companies and the register of mortgages and charges of such companies) or to obtain copies of lists of shareholders of these companies. Our directors will have discretion under our Amended and Restated Memorandum and Articles of Association to determine whether or not, and under what conditions, our corporate records may be inspected by its shareholders, but we are not obliged to make them available to the shareholders (subject to limited circumstances in which an inspector may be appointed to report on the affairs of our Company). This may make it more difficult for you to obtain the information needed to establish any facts necessary for a shareholder motion or to solicit proxies from other shareholders in connection with a proxy contest.

The courts of the Cayman Islands are unlikely (i) to recognize or enforce judgments of courts of the United States predicated upon the civil liability provisions of the federal securities laws of the United States or any state securities laws; and (ii) in original actions brought in the Cayman Islands, to impose liabilities predicated upon the civil liability provisions of the federal securities laws of the United States or any state securities laws, so far as the liabilities imposed by those provisions are penal in nature. In those circumstances, although there is no statutory enforcement in the Cayman Islands of judgments obtained in the United States, the courts of the Cayman Islands will recognize and enforce a foreign money judgment without any re-examination or re-litigation of matters adjudicated upon, provided such judgment: (a) is given by a foreign court of competent jurisdiction; (b) imposes on the judgment debtor a liability to pay a liquidated sum for which the judgment has been given; (c) is final; (d) is not in respect of taxes, a fine or a penalty; (e) was not obtained by fraud; and (f) is not of a kind the enforcement of which is contrary to natural justice or the public policy of the Cayman Islands. Subject to the above limitations, in appropriate circumstances, a Cayman Islands court may give effect

in the Cayman Islands to other kinds of final foreign judgments such as declaratory orders, orders for performance of contracts and injunctions.



## [Table of Contents](#)

***We are permitted to adopt certain home country practices in relation to corporate governance matters that differ significantly from the Nasdaq listing standards. These practices may afford less protection to shareholders than they would enjoy if we complied fully with corporate governance listing standards.***

Certain corporate governance practices in the Cayman Islands, which is our home country, differ significantly from corporate governance listing standards as, except for general fiduciary duties and duties of care, Cayman Islands law has no corporate governance regime which prescribes specific corporate governance standards. To the extent we choose to follow home country practice with respect to corporate governance matters, our shareholders may be afforded less protection than they otherwise would have under corporate governance listing standards applicable to U.S. domestic issuers.

As a result of all of the above, our shareholders may have more difficulty in protecting their interests in the face of actions taken by management, members of the board of directors or controlling shareholders than they would as public shareholders of a company incorporated in the United States.

***The ability of our operating subsidiaries in certain Asia markets to distribute dividends to us may be subject to restrictions under their respective laws.***

We are a holding company, and our operating subsidiaries may be located in Singapore, Thailand, the Philippines, Indonesia, India, Australia, or PNG. Part of our primary internal sources of funds to meet its cash needs will be its share of the dividends, if any, paid by our operating subsidiaries. The distribution of dividends to us from the operating subsidiaries in these markets as well as other markets where we may operate is subject to restrictions imposed by the applicable laws and regulations in these markets.

***It is not expected that we will pay dividends in the foreseeable future.***

It is expected that we will retain most, if not all, of its available funds and any future earnings after the Business Combination to fund the development and growth of its business. As a result, it is not expected that we will pay any cash dividends in the foreseeable future.

Our board of directors have complete discretion as to whether to distribute dividends, subject to certain requirements of Cayman Islands law. In addition, our shareholders may by ordinary resolution declare a dividend, but no dividend may exceed the amount recommended by our directors. Under Cayman Islands law, a Cayman Islands company may pay a dividend out of either profit or share premium account, provided that in no circumstances may a dividend be paid if this would result in the company being unable to pay its debts as they fall due in the ordinary course of business. Even if the board of directors decides to declare and pay dividends, the timing, amount and form of future dividends, if any, will depend on the future results of operations and cash flow, capital requirements and surplus, the amount of distributions, if any, received by us from our operating subsidiaries, our financial condition, contractual restrictions and other factors deemed relevant by the board of directors. Holders of our Securities should not rely on an investment in our Securities as a source for any future dividend income. You may not realize a return on your investment in our Securities and you may even lose your entire investment in our Securities.

### **Risks Related to Taxation**

***We may not achieve the intended tax efficiencies of our corporate structure and intercompany arrangements, which could increase our worldwide effective tax rate.***

Our corporate structure and intercompany arrangements, including but not limited to the manner in which we conduct our intercompany and related party transactions, are intended to provide us with worldwide tax efficiencies. The application of tax laws of various jurisdictions to our business activities is subject to interpretation and also depends on our ability to operate our business in a manner consistent with our corporate structure and intercompany arrangements. The tax authorities of jurisdictions where we operate may challenge our methodologies for intercompany and related party arrangements, including but not limited to transfer pricing, or determine that the manner in which we operate does not achieve the intended tax consequences, which could increase our worldwide effective tax rate and adversely affect our business, financial position and results of operations.

A certain degree of judgment is required in evaluating our tax positions and determining our provision for income taxes. In the ordinary course of business, there are many transactions and calculations for which the ultimate tax determination is uncertain. For example, our effective tax rate could be adversely affected by lower than anticipated earnings in markets where we have lower statutory rates and higher than anticipated earnings in markets where we have higher statutory rates, by changes in foreign currency exchange rates or by changes in the relevant tax, accounting and other laws, regulations, principles and interpretations. Any of these factors could adversely affect our business, financial position and results of operations.

***We could face uncertain tax liabilities in various jurisdictions in which we operate, which could adversely impact our operating results.***

We are subject to the tax laws and policies of each of the countries in which we operate. Since legislation and other laws and regulations (particularly in relation to tax) in emerging markets, such as the markets where we operate, are often undeveloped and the

## [Table of Contents](#)

interpretation, application and enforcement of tax laws and policies in emerging market countries is uncertain, there is a risk that we may be unable to determine our taxation obligations with certainty.

We obtain external tax advice from time to time on the application of tax laws to our operations. Due to the aforementioned challenges of interpretation and consistency of application and enforcement, obtaining such advice may be difficult and opinions on the law may differ. The determination of our provision for tax liabilities requires significant judgment and estimation and there are classifications, transactions and calculations where the ultimate tax payable is uncertain.

Our tax exposure and obligations exist in each of the jurisdictions in which we presently operate and may arise in other jurisdictions in the future in the event that we commence operations in such new jurisdictions, either organically or through acquisitions. These risks may increase when we acquire a business, particularly to the extent that there are limitations or restrictions on the scope or nature of the financial, tax and other due diligence investigations that we are able to undertake in connection with the acquisition, or where the vendors withhold material information. Given the nature of our business, we are also exposed to the general changes in digital taxation policy that are happening globally.

From time to time, we establish provisions to account for uncertainties as well as timing and accounting differences in respect of income tax and indirect taxes, including but not limited to in relation to businesses that are acquired by us. While we have established our tax and other provisions using assumptions and estimates that we believe to be reasonable, these provisions may prove insufficient given the risks and uncertainties inherent in the taxation systems in the countries where we operate. Any adverse determinations by a revenue authority in relation to our tax obligations may have an adverse effect on our business, financial condition and results of operations, and may adversely impact our operations in the relevant jurisdiction and our reputation.

***We may be or become a passive foreign investment company (“PFIC”), which could result in adverse U.S. federal income tax consequences to U.S. Holders.***

For U.S. federal income tax purposes, we will be a passive foreign investment company (“PFIC”) for any taxable year in which, after the application of certain look-through rules with respect to subsidiaries, either (i) at least 75% of our gross income consists of passive income or (ii) at least 50% of the average value of our assets (generally determined on a quarterly basis) consists of assets that produce, or are held for the production of, passive income. Passive income generally includes dividends, interest, rents, royalties, and certain capital gains. Cash is generally a passive asset. Goodwill is active to the extent attributable to activities that produce or are intended to produce active income. Based on the current and projected composition of our income and assets, and the expected value of our assets, including goodwill, which is based on the expected price of our Ordinary Shares, we do not expect to be a PFIC for the current taxable year. However, because PFIC status is determined on an annual basis, and any determination of PFIC status may not be known until the close of each taxable year in question, and our PFIC status for the current taxable year and any future taxable year will depend upon the future composition of our income and assets, there can be no assurance that we will not be a PFIC for any taxable year.

If we are a PFIC for any taxable year during which a U.S. investor holds Ordinary Shares, we generally would continue to be treated as a PFIC with respect to that U.S. investor for all succeeding taxable years during which the U.S. investor holds such Ordinary Shares, even if we ceased to meet the threshold requirements for PFIC status. In such case, such a U.S. investor generally will be subject to adverse U.S. federal income tax consequences, including (i) the treatment of all or a portion of any gain on disposition of Ordinary Shares as ordinary income, (ii) the application of a deferred interest charge on such gain and the receipt of certain dividends and (iii) compliance with certain reporting requirements. We do not intend to provide the information that would enable investors to make a qualified electing fund election that could mitigate the adverse U.S. federal income tax consequences should we be a PFIC. You are urged to consult your tax advisor concerning the U.S. federal income tax consequences of owning and disposing of Ordinary Shares if we are to become classified as a PFIC.

For further discussion, see “Taxation—Material United States Federal Income Tax Consideration.”

## **ITEM 4. INFORMATION ON THE COMPANY**

### **A. History and Development of the Company**

We were incorporated as an exempted company limited by shares on December 28, 2022. Upon the consummation of Business Combination on August 25, 2023, “noco-noco Inc.” (formerly known as Prime Number Holding Limited) became the ultimate corporate parent of our Group. On August 28, 2023, our Ordinary Shares and Warrants commenced trading on the Nasdaq Capital Market (“Nasdaq”) under the symbols “NCNC” and “NCNCW,” respectively.

The legal name of the Company is noco-noco Inc. The Company was incorporated as an exempted company limited by shares on December 28, 2022. The Company has been the consolidating entity for purposes of noco-noco’s financial statements since the

consummation of the Business Combination on August 25, 2023. The history and development of the Company and the material terms of the Business Combination are set forth in the Form F-4 in the sections entitled “Summary of the Proxy Statement/

## [Table of Contents](#)

Prospectus,” “The Business Combination Proposal,” “Information related to PubCo” and “Description of PubCo Securities,” which are incorporated herein by reference. See “Explanatory Note” in this Report for additional information regarding the Company and the Business Combination. Certain information about the Company is set forth in “Item 4.B — Business Overview” and is incorporated herein by reference. The material terms of the Business Combination are set forth in Item 10 of this Report.

The Company’s registered office is at 89 Nexus Way, Camana Bay, Grand Cayman, KY1-9009, Cayman Islands, and its principal executive office is 4 Shenton Way, #04-06 SGX Centre II, Singapore 068807. The Company’s principal website address is [www.noco-noco.com](http://www.noco-noco.com). We do not incorporate the information contained on, or accessible through, the Company’s websites into this Report, and you should not consider it a part of this Report. The SEC maintains an Internet site that contains reports, proxy and information statements, and other information regarding issuers that file electronically with the SEC. The SEC’s website is [www.sec.gov](http://www.sec.gov).

### **B. Business Overview**

*The following discussion reflects the business of noco-noco. Unless the context otherwise requires, all references in this section to the “Company,” “we,” “us,” “our” or “noco-noco” refers collectively to noco-noco Inc. and its subsidiaries.*

#### **Overview**

We are an early-stage decarbonization solution provider in Asia, aiming to primarily engage in (i) the leasing of battery products, including batteries and BEVs to commercial transportation companies, and of ESS to renewable power plants and other power plants requiring grid stabilization and backup power; and (ii) carbon abatement solutions for landowners and carbon credit sales.

We operate a unique own-and-lease business model where we manufacture, upon our clients’ requests, our battery products through OEMs and lease them to our clients. The own-and-lease business model, as compared to sales of battery products, helps our clients save upfront investment and operation capital expenditure. Under such business model, we also partner with automakers and OEMs to conduct our leasing business in the regions where our partners operate, to protect ourselves from capital, operational, and local regulatory risks.

We rely on our exclusive license-in agreement with 3DOM Alliance to utilize its state-of-the-art intellectual property and technologies to develop and manufacture our own battery products and services. These state-of-the-art technologies enable us to produce batteries that we believe, as compared to conventional batteries, are designed to have a longer lifespan and higher reliability, and be more resistant to high operating temperature and thermal runaways. Our unique position with 3DOM Alliance as the exclusive licensee of its patents and technologies also allows us to take full advantage of the technology advancement that 3DOM Alliance has developed or licensed in through various cooperation and collaboration arrangements with leading universities and professors for our battery products. To scale our business and to improve our productivity, we also entered into several MOUs with our strategic partners, including primarily well-known automakers and battery manufacturers.

In addition, we engage in carbon abatement solutions and carbon credit sales. We work with our landowner clients to reduce their excessive carbon emissions and generate carbon credits. These carbon credits can be sold back to the regulators, or on the secondary market through our network of clients, the revenue generated from which is shared between our landowner clients and us. We sell the carbon credits to companies in need of carbon offsets through our active marketing efforts. We also cross-sell them to our battery business clients to offset carbon emissions from their operations, in addition to leasing them our battery products. As our battery business clients are generally under pressure to decarbonize their business operations, our cross-selling of carbon credits in addition to our leasing business will increase our competitiveness and generate synergies among our product and service offerings.

Leveraging the state-of-the-art technologies of our battery products, our unique own-and-lease business model as well as the cross-selling to our battery business clients of carbon credits gained through our carbon abatement solutions, we believe we are well positioned to capitalize on the global momentum towards electrification of transportation and the global carbon emission reduction goal.

#### **Our Competitive Strengths**

We believe the following competitive strengths have contributed to our maturity and will help drive our growth in the future.

##### ***State-of-the-art Technologies Enables Highly Reliable and Longer-lasting Battery Products***

We license in a series of state-of-the-art patents and technologies from 3DOM Alliance, our majority shareholder, with respect to, among others, battery cascade use, battery management system, battery cell and pack model, and battery units. These technologies

enable us to produce batteries that, as compared to conventional batteries, are designed to have a longer lifespan and higher reliability, and be more resistant to high operating temperature and thermal runaways. For example, due to the higher porosity and uniformly spaced 3-dimensional structure of the pores of our separators, ionic conductivity becomes more efficient, thus reducing the formation

## [Table of Contents](#)

of dendrites, which are the major source of battery unsafe risks, such as fire, quick deterioration, and poor resilience to high temperatures. Further, with the high porosity, our separators are much more wettable than conventional separators. This enables the use of high-viscosity, low-volatility electrolytes in our batteries, increasing their resistance to fire or degradation from heat and high temperatures. Thus, our batteries can also avoid the rapid deterioration resulting from intense heat conditions, which cause problems to conventional batteries with low-viscosity electrolytes.

In addition, our unique position with 3DOM Alliance as the exclusive licensee of its patents and technologies allows us to take full advantage of the technological advancement that 3DOM Alliance has developed or licensed in through various cooperation and collaboration arrangements with leading universities and professors for our battery products. For example, Professor Kiyoshi Kanamura, a leading Japanese authority in battery research and the chief technology officer of 3DOM Alliance, licensed the exclusive right of his patent “secondary battery separator and lithium secondary battery using the separator” to 3DOM Alliance in October 2011. This critical patent enables 3DOM Alliance to develop, and us to use, manufacture, and lease, our highly-reliable and long-life batteries. 3DOM Alliance also received technical support from a well-known university in Japan for its R&D of highly-reliable and long-life battery separators, supplementing 3DOM Alliance’s R&D capabilities. The cooperation with and support received from leading universities and professors is a recognition of 3DOM Alliance’s R&D capabilities in the battery industry, which enables us to produce highly-reliable and long-life batteries to better serve our clients’ interests.

### ***Unique Own-and-Lease Business Model Makes Our Battery Products Cost-effective***

We operate a unique own-and-lease business model where we manufacture upon our clients’ requests, through OEMs, our battery products, including batteries, BEVs and ESS, and lease them to our clients, primarily consisting of commercial transportation companies, renewable energy plants and other power plants requiring grid stabilization and backup power in Asia. Traditionally, it would cost tremendous upfront capital expenditure and operation expenses for companies to purchase the battery products. However, under our own-and-lease business model, our clients only need to lease our battery products without having to purchase them, enabling our clients’ operation of BEVs and renewable energy plants more affordable. In addition, due to the advanced technology licensed-in from 3DOM Alliance, our batteries generally have a lifespan doubling that of conventional batteries, which indicates our batteries generally have approximately 30% to 35% lower price per cycle as compared to conventional batteries. Based on an internal evaluation, our X-SEPA battery with a 1C rate was tested over 4,500 cycles, and by applying the square root law to the test results, was found to be able to continue for 6,000 cycles before decreasing to a state of health (“SOH”) of 60%. A similar battery using a conventional separator, however, can last only 2,800 cycles before decreasing to an SOH of 60%. Evaluations in March 2023 produced more impressive results, with the life of our X-SEPA battery achieving 6,400 cycles at a higher SOH of 70%. Recent evaluations in April 2023 showed that our X-SEPA battery equipped with high temperature-resistant electrolyte was found theoretically possible to achieve approximately 9,000 cycles before decreasing to an SOH of 60%. The longer lifespan of our batteries also entitles our batteries to have two useful lives — our batteries can be used in BEVs for e-motorbikes, e-vans, e-buses, and e-trucks in their first life cycle (typically for lease up to eight years), and then in ESS for renewable power plants and other power plants requiring grid stabilization and backup power in their second life cycle (typically for lease up to ten years). This cascade usage model, with the long-term instalment of lease payments, is expected to help us attract clients whose operation is capital intensive.

As high capital expenditure is a major deterrence to the electrification of the transportation industry and also the transformation from fossil fuel power to renewable power, we believe our own-and-lease business model is essential to accelerate the transitioning from ICE vehicles to BEVs and the universal use of ESS to support and optimize renewable power generation.

### ***Strategic Cooperation and Partnerships with Market Players***

We have entered into a series of MOUs with well-known automakers and OEM partners to establish strategic business partnerships, with the ultimate goal of deploying our batteries in certain of their forthcoming battery powered EVs. For example, we have entered into an LOI with B-ON K.K. (“B-ON”) to employ our battery cells for its 3- and 4-wheeled electric light commercial vehicles. We believe the successful joint development of battery technologies as well as the incorporation of our batteries into well-known automakers’ vehicles will enormously expand our business and operations as well as enhance our brand name.

In addition, we intend to cooperate with an e-waste recycling service provider to collect our used batteries to synergize with our carbon abatement solution business.

### ***Carbon Abatement and Credit Generation Capability Add Value to Our Leasing Business***

We assist our clients, primarily landowners of forests, mangrove, bushland or land of similar kinds, to reduce their carbon emissions or absorb carbon, and earn carbon credits generated from the carbon abatement projects. Specifically, we plan methodologies of reducing and/or removing carbon emissions while creating revenue by operating a general carbon credit account, procuring carbon credits through submission to regulators, and securing subsequent buyers for sales of carbon credits, leveraging our information technology, science and mapping capabilities. We typically form a joint venture or partnership with our clients to carry out

the carbon abatement projects. When certain requirements and criteria of carbon emissions are met, our clients can apply for carbon credits from government-introduced regulators. These carbon credits can be sold back to these regulators, or on the secondary



## [Table of Contents](#)

market through our network of clients, revenue generated from which is shared according to a pre-agreed ratio between our landowner clients and us.

In addition, leveraging our carbon credits generation capability, we are able to cross-sell the carbon credits generated through our carbon abatement projects to our battery product clients, who are keen to reduce their carbon emissions generated during their operations. As these clients are typically under pressure to decarbonize their business operations, our cross-selling of carbon credits in addition to our leasing business we believe will increase our competitiveness and generate synergies among our product and service offerings. In particular, with our carbon credit generation capability, we are able to provide leasing services and carbon credit sales in a bundle, on the one hand, helping our battery product clients to offset the carbon emissions generated by their operations, and on the other hand, improving our clients' stickiness and generating additional profits. The synergies between our two business segments earn us both preference by our clients and strategic cooperation opportunities. For example, B-ON entered into an LOI with us, intending to cooperate on commercial car lease with available carbon credits. As zero carbon has become a global goal and international tradability of carbon credits has become available and popular, we believe we are well positioned to potentially reap substantial returns from the synergies and cross-selling between our battery business and carbon credits business.

### ***Experienced Management and Synergy with 3DOM Alliance***

We are led and influenced by an experienced CEO, Mr. Masataka Matsumura, who is deeply rooted in the battery industry. Mr. Matsumura's deep business insights have driven the sustainable development of our strategic business direction. His strategic vision and thorough understanding of the battery industry helps us make crucial business decisions based on market trends and development.

Since our inception, we have received strong support from, and achieved great synergy with, our majority shareholder, 3DOM Alliance. 3DOM Alliance is a forerunner in the R&D of battery technologies, including battery separators and lithium-ion batteries, which has been named as an innovation project by the New Energy and Industrial Technology Development Organization for two consecutive years. Benefiting from the market recognition of the "3DOM" brand, we believe we are well positioned to promote our service offerings among our clients and differentiate ourselves from our competitors.

### **Our Decarbonization Solutions**

We are an early-stage decarbonization solution provider in Asia, aiming to primarily engage in (i) the leasing of battery products, including batteries and BEVs to commercial transportation companies, and of ESS to renewable power plants and other power plants requiring grid stabilization and backup power; and (ii) carbon abatement solutions for landowners and carbon credit sales.

### ***Own-and-Lease of Battery Products***

We operate a unique own-and-lease business model where we manufacture, upon our clients' requests, our battery products through OEMs, including batteries, BEVs and ESS, and lease them to our clients, primarily consisting of commercial transportation companies, renewable energy plants and other power plants requiring grid stabilization and backup power in Asia. Traditionally, it would cost tremendous upfront capital expenditure and operation expenses for companies to purchase the battery products. However, under our own-and-lease business model, our clients only need to lease our battery products without having to purchase them, enabling operation of BEVs and renewable energy plants more affordable. Alternatively, our clients are also able to place orders to customize their battery products with specific specifications using the licensed-in X-SEPA separator technology. See "*— Our Pipeline Products and Services — X-SEPA Separator.*" We expect to generate revenue from our leasing business of battery products during the fourth quarter of 2024.

### ***Leasing of Batteries and BEVs***

We plan to partner with automakers and manufacturers to conduct our leasing business of batteries and BEVs. We plan to cooperate with automakers as OEMs to produce BEV bodies upon orders placed by our clients to satisfy their demand. We also plan to engage battery manufacturers as OEMs for the mass manufacturing of our highly reliable and long-life batteries, which will be applied to our BEVs. Our BEVs are expected to be leased to our clients at a cost-effective rate to attract more clients and achieve our competitiveness among our competitors. These BEVs may include e-buses, e-vans, e-trucks, e-motorbikes, and last-mile delivery vehicles. We expect to focus our operations in the Southeast Asia and South Asia, including Thailand, the Philippines, Indonesia, India, and Singapore. In addition, we plan to leverage our in-house battery management system ("**BMS**") integrated with data process and mesh networking technologies to optimize energy usage of our battery products and to develop intelligent batteries.

### ***Leasing of ESS***

We plan to lease our ESS incorporating our highly reliable and long-life batteries to power producers, including renewable energy plants and other power plants requiring grid stabilization and backup power. We also expect to provide key technological

solutions to help resolve battery-related issues in our clients' energy storage process. With our highly reliable and long-life batteries and systems that can monitor battery conditions and allocate batteries for primary or secondary use, we believe our clients will be able

## [Table of Contents](#)

to lower the costs of their energy storage solutions. In addition, we plan to explore together with our clients on opportunities to apply our batteries to a broader coverage of energy storage, including developing battery systems for the electrification of commercial vessels, and using battery tankers to transport energy from offshore farms to onshore ones.

### ***Carbon Abatement Solutions and Carbon Credit Sales***

We provide our carbon abatement solutions to help our clients reduce their excessive carbon emissions and generate carbon credits. Specifically, we plan methodologies of reducing and/or removing carbon emissions while creating revenue by operating a general carbon credit account, procuring carbon credits through submission to regulators, and securing subsequent buyers for sales of carbon credits, leveraging our information technology, science and mapping capabilities. We typically form a joint venture or a partnership with our landowner clients to carry out the carbon abatement projects. See “— *Key Terms of Carbon Abatement Project Agreement*” for more details regarding the arrangements of our carbon abatement projects.

We undertake extensive geography survey mapping to create an overlay of the potential target areas, and identify existing and new activities in land, vegetation, crops and others to analyze their carbon abatement potentials. By using carbon-based feasibility studies, geo-fencing and land analysis, we map the farming enterprise and calculate the current emissions. For example, we conduct on-ground site measurements combined with satellite mapping to mark the area that can be covered under subsequent applications, and assess the current status of the vegetation and carbon capture and prepare a roadmap for future development of the area to further enhance the carbon absorption potential. Thus, we can project the reduction in emissions based on each modeled, recommended change from the initial farm carbon deficit to increase value for the project by creating new registerable carbon credits. Initial set up costs, including mapping and feasibility study costs, are disbursed by the landowners. Subsequently, we prepare an application for each carbon abatement project with the relevant government regulators, which identifies the specific land and provides extensive mapping data. Upon the submission of the application, the regulators will determine the value of the carbon abatement projects based on the application material and allocate a certain amount of carbon credits based on the mapping, type, volume and lifetime of the land.

Our carbon abatement projects primarily include carbon farming projects, deforestation avoidance projects, and rural afforestation projects. Carbon farming projects use farming in a way that reduces greenhouse gas emissions or captures and holds carbon in vegetation and soils. We provide consultancy and assistance to landowners while working cohesively to set up and commence carbon farming activities to reduce carbon emission and earn carbon credits. For deforestation avoidance projects, we work with landowners to promote agricultural planning and production that avoids tree-clearing, advocating stronger biodiversity to protect rural habitat. In parallel, we campaign for a halt to deforestation across the Asia-Pacific. A reforestation and afforestation project involves planting trees in agricultural areas. In doing so, the project helps to reduce the amount of greenhouse gas entering the atmosphere, as carbon stock remains stored in the trees while they grow.

We also execute for our clients the sales of their carbon credits generated during the process of carbon abatement projects. When certain requirements and criteria of carbon emissions are met, our clients can apply for carbon credits from government-introduced regulators. These criteria include definitive action plans to re-afforest the land tracts, conversion of methane generated from livestock in the farms into an alternative energy sources, and implementing a consisting clearing and pruning of grassland farms to avoid savannah burning from dry grass, to name a few. The carbon credits can be sold back to the regulators, or on the secondary market through our network of clients, revenue generated from which is shared according to a pre-agreed ratio between our landowner clients and us. We sell the carbon credits to companies in need of carbon offsets through our active marketing efforts. We also cross-sell these carbon credits to our battery product clients, in addition to leasing them our battery products.

Our business of carbon abatement solutions and carbon credit sales currently primarily operates in Australia and PNG, and expects to expand into Indonesia, the Philippines, and Fiji in the future. According to the relevant laws and regulations in Australia and PNG, no specific license is required to conduct the business.

#### Australia

In Australia, we offer carbon abatement projects using a variety of agricultural methods that sequester atmospheric carbon in soil, crop vegetation, and biomass. Our solutions include storing carbon in their soils, planting native trees and shrubs, managing stock to allow native forest to regrow, beef herd improvement, and reducing nitrous oxide emissions from irrigated crops. With these carbon-neutral effects, we can assist these landowners to set up ERF projects and apply for ACCUs. The ACCUs can be used by landowners to offset their carbon emissions, are tradable in the secondary markets, and can be sold back to the CER, the authority that administers the ERF which supplies ACCUs.

#### *ERF Projects*

We submit for individual carbon project on the ERF government portal for approvals of issuance of an ERF carbon contract or credits. We are entitled to conduct carbon abatement projects on the sites within Australia and PNG and can claim carbon credits for

emission abatement achieved by such projects.

## [Table of Contents](#)

Carbon credits are issued upon acceptance of the carbon abatement project by the CER. We are responsible for facilitating the processes of auditable reports, carbon project registrations, carbon abatement contracts and other display information required for the issuance, marketing, auditing, and accounting of carbon credits through the Australian National Registry of Emissions Units for auction or re-sale in the carbon market.

We can sell the carbon credits to third parties via auction or direct sales in the carbon market. We can use the Carbon Market Institute Carbon Marketplace for auction of the carbon credits, or sell the carbon credits directly to third parties through our worldwide network that are under pressure to reduce carbon emission for direct sales. As of the date of this Report, we had contracted and submitted six carbon abatement projects to the CER, totaling 65,000 hectares and are estimated to produce around 1 million ACCUs.

### PNG

The carbon market in PNG operates differently to that of the Australia as a result of minimal regulatory frameworks in place. There are voluntary carbon schemes and governmental schemes in PNG, which are agreements negotiated directly with landowners with little governmental intervention.

Following the 26th United Nations Climate Change Conference of Parties in Glasgow (COP 26), Australia, Fiji and PNG have collaborated to generate high-integrity carbon offsets in the Indo-Pacific market by virtue of the Indo-Pacific Carbon Offsets Scheme. See “— *Government Regulations.*”

As of the date of this Report, we have contracted to deliver over 30 carbon abatement projects in PNG, totaling 5.3 million hectares and are estimated to produce around 159 million tons PNG carbon credits. In addition, as of the same date, we had successfully submitted 11 of these carbon abatement projects, totaling 4.3 million hectares and producing around 128 million carbon credits.

On August 29, 2023, the Climate Change and Development Authority (“CCDA”) of PNG acknowledged, by way of an official letter, its support for two carbon abatement projects in PNG that have been submitted by a subsidiary of Hop2it Holdings Pte. Ltd. (“Hop2it”) to the CCDA.

These two projects, amongst more than 30 contracted projects secured by Hop2it in PNG involve deforestation avoidance. The shareholders of Hop2it, which are noco-noco and two minority shareholders, have a restructuring deed with noco-noco Pte. Ltd., whereby 52% of the profits from Hop2it’s carbon abatement projects will be paid to us. Furthermore, under the terms of the deed, Hop2it’s carbon abatement management business and all future potential economic benefits of Hop2it’s carbon abatement management business will be carried out through and assigned to noco-noco Australia Pty Ltd., a subsidiary of ours, 52% of which is owned by noco-noco and 48% of which is owned by the minority shareholders of Hop2it.

The first two projects that the CCDA has reviewed are (1) the An Orumako Customary Landowner Area in the Kikori District, Gulf Province, and (2) the Cloudy Bay Customary Landowner Area in the Abau District, Central Province. The size of these land plots are 52,750 hectares and 148,434 hectares respectively. The CCDA recognizes that:

- The two projects are submitted under the National REDD+ Methodology and Development Guidelines adopted by PNG and have been worked on and submitted to the CCDA by Hop2it as the REDD+ qualified Proponent, and with the Natural Forest Standard (“NFS”) in the United Kingdom as the Creditor, who have provided preferred Verification Validation Body (“VVB”) to Hop2it, to vet and work with to harvest Carbon Credit Units.
- The two parties, Hop2it and NFS, are working on completing the Project Design Documents (“PDD”), which will qualify NFS for Permit Issuance by the CCDA, once the PNG moratorium on new REDD+ projects (which has been in place since March 2022) is lifted.

### Key Terms of Carbon Abatement Project Agreement

We typically form a joint venture or a partnership with our landowner clients to carry out the carbon abatement projects in Australia and PNG, the key terms of which are set out below:

*Purpose of the joint venture or partnership.* The parties form a joint venture or a partnership to combine expertise, management and property resources to support reduction of emissions and produce additional revenue for our clients through the issue of carbon credits for sale on the domestic and international markets.

*Service term and renewal.* The agreement typically remains in full force and effect from its date up to 2030 (the “**Initial Term**”). Upon the expiration of the Initial Term, the agreement shall be automatically renewed each time for a successive five-year period until 2050, subject to either party’s prior written notice of termination before the expiration of the Initial Term or any renewed term.



## [Table of Contents](#)

*Our services.* We provide geo-survey services and map all carbon sequestration capabilities of our clients for the purposes of identifying all carbon abatement capabilities of any existing pastured land, vegetation, crops, mangrove, forests or grasslands that may exist on land provided by the clients and to be managed by us. In particular, our services include carbon-based feasibility studies, geo-fencing and analysis of the land for the identification of carbon emissions and submission of contracts and other governmental documents for the issue of carbon credits.

*Regulatory submission and approval.* As the carbon abatement manager and registration agent, we manage the regulatory submission process as well as domestic and international sales and marketing of the carbon credits derived from the carbon abatement projects. In particular, we provide and operate an online portal with the CER, and provide access to government audits and carbon credit certificate issues on account. The government typically issues a valid carbon credit certificate upon an approved carbon project contract within 90 days of submission.

*Sales of carbon.* We sell the carbon credits to third party companies via auction or direct sales in domestic markets, or in international markets through our commercial relationships abroad.

*Distribution of carbon credit sales revenue.* The net proceeds, after deduction of operating expenses and disbursements, are split between the parties at a pre-agreed percentage. Typically, 20% to 60% of the net proceeds will be distributed to us with the rest 80% to 40% distributed to landowner clients and project officers (if any) as a whole.

*Payment schedule.* Our landowners clients and we agree to a guaranteed base price set for an initial term. We arrange to make payments within three working days of the initial deposit made by the government or from international exchange market or direct sales buyers. When profits generated from the carbon abatement projects exceed the base price by a pre-agreed percentage, our landowner clients will receive additional payment.

*Exclusivity.* Due to the specialized nature of the carbon abatement industry and the longevity of our participation in the project, the agreement is entered into on an exclusive basis.

*Confidentiality.* Neither party is entitled to disclose any confidential information relating to the other party's business to any person or entity without the express written consent of the affected party, except as required by law.

*Termination.* Either party may terminate the agreements by prior written notice to the other party at least 30 days before (but in no case more than 60 days before) the expiration of the Initial Term or any renewed term. At any time, the agreement may also be terminated by mutual written consent of the parties. When the agreement expires or terminates, all parties' obligations under the agreement with respect to the operation and administration of the joint venture shall be immediately terminated.

## **Our Pipeline Products and Services**

Our primary pipeline products include (i) X-SEPA separator and (ii) lithium manganese iron phosphate (LMFP) cathode.

### ***X-SEPA Separator***

Our batteries equipped with X-SEPA separator, developed by 3DOM Alliance after eight years of research and development, is more reliable and longer-lasting compared with conventional batteries, due to our X-SEPA separator's high and uniformed porosity, high liquid absorption, and high heat resistance. Below is the illustrative picture of the structure of our batteries using X-SEPA separators:

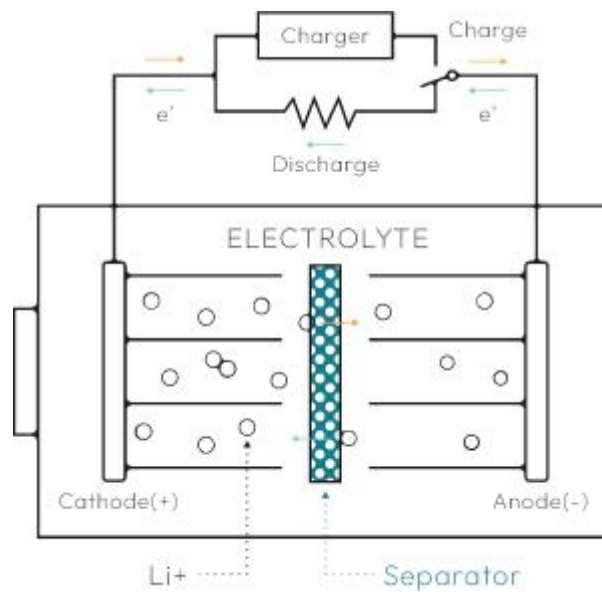

Our X-SEPA separator has the unique advantage of high and uniform porosity, which is the key to high ionic conductivity, resulting in long battery lifespan and the avoidance of dendrite formation, which is the main cause of fire and explosions and fast battery deterioration. X-SEPA separator is capable of having more than 70% porosity, compared to around 40% porosity for conventional separators. Conventional separators are made through a uniaxial stretching method, which can only produce irregularly shaped and randomly distributed pores by tearing. In our case, we are able to produce, through 3DOM Alliance, pores that are uniform and with high density through unique manufacturing process using polyimide precursor with beads and put through a process of drying and detachment, imidization and thermal removal of the beads, hence creating pores that are regular in shape and evenly distributed. Below is the illustrative picture showing the different production methods between a general-purpose PP separator and our X-SEPA separator:

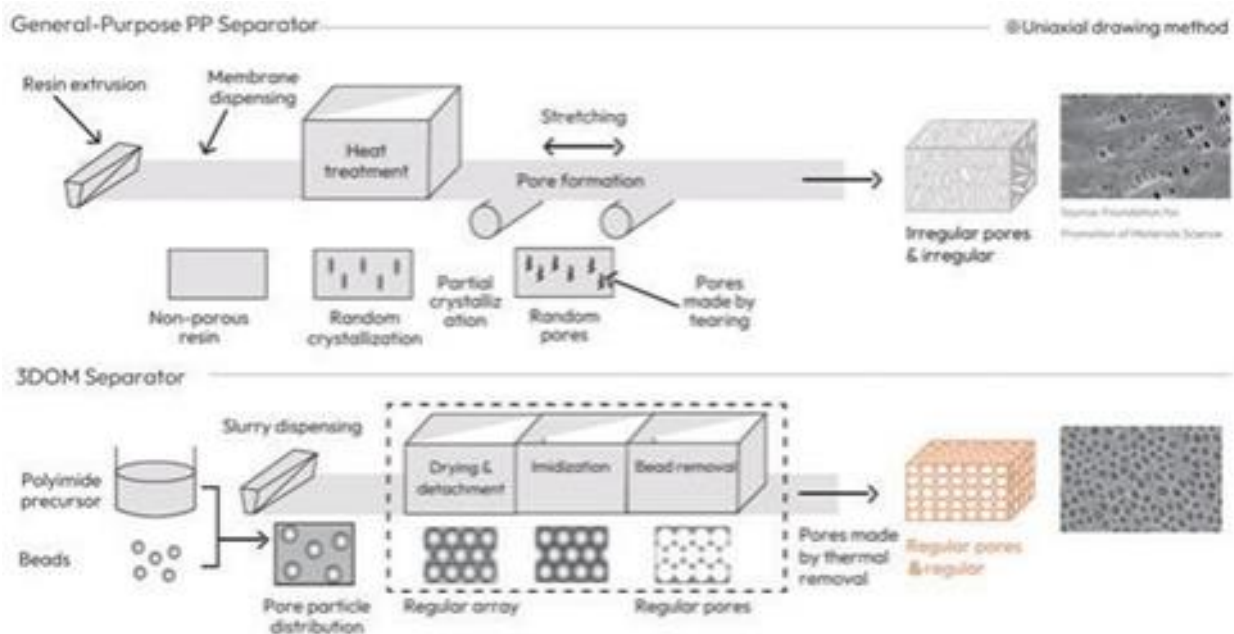



## [Table of Contents](#)

The unique methodology of producing X-SEPA separators enables us to offer customized separators with pre-specified pore sizes and density, which helps achieve desired battery performance parameters. Furthermore, through a 3-layer die configuration, we are now able to offer separators with 3 layers with the middle layer being of low porosity and the two outer layers of high porosity. The middle layer can provide strength to the overall separator, whilst the outer layers of high porosity can increase the lifespan and make possible high C charge/discharge rates for the battery without causing damage and deterioration. Below is the illustrative picture of the structure of our X-SEPA separators:

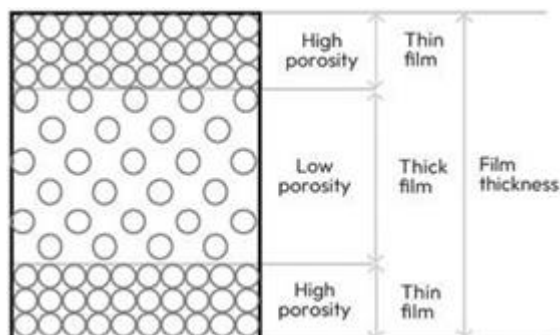

In addition, X-SEPA separator has a high wettability due to its high and uniform porosity. This enables us to use high viscosity electrolytes, which are non-volatile and can prevent explosion. Such electrolytes, which have up to 30 times more viscosity than conventional electrolytes, are also less prone to evaporation at high temperatures, and thus can enhance battery performance. A 25mAh nickel manganese cobalt (NMC) battery, with non-volatile electrolyte and using X-SEPA separator, can last 600 cycles to the point when capacity retention drops to 60% at a temperature of 60 degrees Celsius and at 0.5C charge/discharge rate. A similar battery without X-SEPA separator can last only 370 cycles in the same condition. X-SEPA separator is hence essential for producing batteries which can withstand very high operating temperature conditions without fast deterioration of battery function.

Furthermore, our batteries, with the X-SEPA separator fitted in, are found to be high heat resistant, have high reliability in abnormal conditions and a near doubling of lifespan of other batteries. Capacity retention of our battery with X-SEPA separator only falls to 60% after 7,300 cycles, at an operating temperature of 25 degrees Celsius and a 1C rate, whereas a battery without X-SEPA separator drops to 60% retention after 3,300 cycles in the same condition. If the operating temperature goes up to 45 degrees Celsius, our battery falls to 60% retention after 3,600 cycles whilst the other can last only 1,450 cycles. In a recent testing at 60 degrees Celsius, our battery was able to reach 2,000 cycles before retention capacity dropped to 80%, which was approximately five times of the cycles achievable by other batteries. Nail penetration testing on the battery cell with a conventional separator had resulted in thermal runaway and venting, corresponding to European Council for Automotive R&D (“EUCAR”) hazard level 4, while testing on the battery cell equipped with our X-SEPA separator did not result in thermal runaway and produced no smoke or flame, corresponding to EUCAR hazard level 2.

The high uniform porosity of X-SEPA separator also makes it highly suitable for lithium-metal anode, solid-electrolyte batteries. A lithium-metal anode battery sample was developed and tested in July 2020, with successful achievement of 200 cycles for 400Wh/kg energy density. We expect the mass production of single layer separator to begin in the fourth quarter of 2024, and 3-layer samples have been provided for client testing since February 2023. Mass manufacturing of 3-layer separator is targeted to commence in the fourth quarter of 2024. The manufacturing of X-SEPA separators is expected to be carried out by 3DOM Alliance and OEMs.

Below is a diagram showing the differences between conventional batteries and our batteries using X-SEPA separators:

CONVENTIONAL SEPARATOR

3DOM SEPARATOR

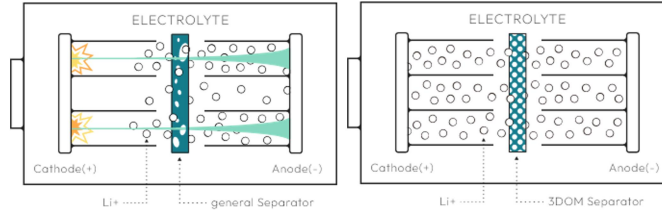

Material	polypropylene / polyethylene	polyimide
Pore structure	uneven and 2-dimensional	even and 3-dimensional
Porosity	about 40-50%	over 60%
Heatproof temperature	150 - 250 °C	400°C or higher

## [Table of Contents](#)

### ***Lithium Manganese Iron Phosphate (LMFP) Cathode***

Lithium iron phosphate (LFP) batteries are increasingly used in place of nickel cobalt aluminum (NCA) and nickel manganese cobalt (NMC) batteries which are more expensive, but LFP batteries have the disadvantage of lower energy density. In 2014, 3DOM Alliance developed a battery using a cathode fabricated with lithium-manganese-iron-phosphate (LMFP), which has more energy density and cost less, as compared with LFP batteries. Our LMFP batteries developed by 3DOM Alliance have about 30% higher energy density than LFP batteries and a lifespan of about 6,000 cycles compared to 3,000 cycles for third party LFP batteries. Although the average cost of our LMFP batteries is higher than that of the LFP batteries, due to the much longer lifespan, cost of our LMFP batteries per cycle is about 35% lower. We expect to commence commercialization of the LMFP cathode in the fourth quarter of 2024.

### **Relationship with 3DOM Alliance**

3DOM Alliance is our majority shareholder which engages in the R&D of various battery technologies. The history of 3DOM Alliance can be traced back to 2011 when the patent of “secondary battery separator and lithium secondary battery using the separator” was granted by Japan Patent Office to Professor Kiyoshi Kanamura, and subsequently licensed exclusively to 3DOM Technology Inc., the predecessor of 3DOM Alliance. During 2015 to 2017, 3DOM Alliance was among the list of technology innovation projects and enjoyed a series of governmental and university support. In 2018, 3DOM Alliance began making samples of solid-state batteries, and later in the following year, delivered the first supply of batteries using its proprietary battery technology to a BEV maker. In 2019, 3DOM Alliance also began the development of application for ESS. In 2020, 3DOM Alliance installed a small-scale production line for its separator X-SEPA, producing lithium-metal anode battery samples for testing.

We entered into an exclusive, irrevocable license-in agreement with 3DOM Alliance, on November 22, 2022, enabling us to manufacture our battery products with 3DOM Alliance’s cutting-edge technologies. Pursuant to our agreement, 3DOM Alliance granted us certain of its proprietary and licensed-in patents and other intellectual properties, as well as confidential know-how and other information, relating to, among others, battery cascade use, battery management system, battery cell and pack module, leasing with carbon credit, business model task distribution equipment, battery unit, electronic equipment control equipment communication terminals and electronic equipment, degradation-based billing prediction, and degradation-based billing forecasting (“**3DOM IP Rights**”).

### ***Key Terms of the License-in Agreement***

Below set out the key terms of the license-in agreement entered by 3DOM Alliance and us:

*Term:* The term of the license-in agreement is perpetual, unless terminated upon default, or upon bankruptcy or insolvency.

*Grant of license:* 3DOM Alliance grants us a worldwide, exclusive, irrevocable license on 3DOM IP Rights to make, import, export, use, or sell products which incorporates or is the result of the licensed 3DOM IP Rights (“**Licensed Product**”).

*Technical assistance:* 3DOM Alliance shall provide technical assistance for us to utilize 3DOM IP Rights.

*Right of first refusal:* We have the right of first refusal to enter into negotiations to license in any further intellectual properties from 3DOM Alliance that it owns or acquires, when 3DOM Alliance intends to license out its intellectual properties.

*Exclusivity:* 3DOM Alliance shall not practice or grant to any third parties any license to practice the 3DOM IP Rights within the scope of the license granted to us perpetually.

*Royalties:* We are obligated to pay 3DOM Alliance royalties quarterly within sixty (60) days after the end of each quarter, equal to three percent (3%) of the gross profit generated using each of 3DOM IP Rights. The royalty rate can be revised by mutual written consent. After the first anniversary of the effective date of the license-in agreement, either party shall have the right to negotiate to adjust the royalty rate annually.

*Termination:* Either party can terminate the license-in agreement when the other party fails to pay any amounts when due with a thirty (30) days’ written notice, or when the other party fails to perform any obligation and fails to cure within the sixty (60) days’ notice period. Upon the occurrence of any aforementioned event of default, the non-defaulting party shall deliver to the defaulting party a written notice of intent to terminate, such termination shall be effective upon the date set forth in such notice. 3DOM Alliance may also terminate the license-in agreement with a written notice upon our bankruptcy or insolvency.

*Assignment:* Any and all assignments of the license-in agreement or any granted rights by us are void, except for assigning (i) to any of our affiliates, or (ii) as expressly permitted under the agreement.



## [Table of Contents](#)

*Upfront payment:* We are obligated to pay a one-off, refundable upfront payment of \$30 million licensing fee to 3DOM Alliance. Such upfront payment shall be credited against any royalties under the agreement such that the amount of the upfront payment shall be deducted from the royalties when due and payable. In the event that the upfront payment has any remaining amount after the last deduction from the royalties at the end of a five- year period from the last instalment of the upfront payment, the remaining unutilized amount shall be refunded to us at our request. Pursuant to a supplemental agreement to the license-in agreement dated May 10, 2023 (the “**Supplemental Agreement**”), the upfront payment shall be payable over a series of instalments after the consummation of the Business Combination, in such amounts and pursuant to such repayment schedule as may be agreed between 3DOM Alliance and us. Both parties shall negotiate the installment plan in good faith, taking into consideration our working capital needs as well as our liquidity and available capital resources after the consummation of the Business Combination.

*Obligations related to commercialization:* We shall be responsible for obtaining all necessary governmental approvals for exercising the intellectual property rights under the license-in agreement, including the development, manufacture, distribution, sale and use of any Licensed Product, at our expense, including, without limitation, any safety studies. We shall have sole responsibility for any warning labels, packaging and instructions as to the use of Licensed Products and for the quality control for any Licensed Product. 3DOM Alliance agrees to provide reasonable assistance to our company, including through the provision of 3DOM’s know-hows, with regard to obtaining said approval, exercising the intellectual property rights, and conducting quality control. With regard to commercializing 3DOM IP Rights, we shall regularly coordinate and consult with 3DOM Alliance in developing and implementing our business plans for the earlier of the following periods: the first three years after the execution of the license-in agreement or upon the reasonable determination by 3DOM Alliance that such coordination and consultation is no longer necessary.

*Royalty-free license to improvements:* We shall own all the rights of the improvements to the Licensed Products it creates (the “**Improvements**”) to the extent that such Improvements are not contained within the scope of 3DOM IP Rights. We granted to 3DOM Alliance a non-exclusive, royalty- free license of the Improvements, strictly for 3DOM Alliance’s non-commercial research purposes, without limitation as to time or geographic area, with the right for 3DOM Alliance to sublicense to other non-profit institutions for their non-commercial research purposes.

*Government funding:* Our rights and obligations under the license are subject to change due to 3DOM Alliance’s obligations in connection with any funding or other support from an interested government.

## **Government Regulations**

### *Singapore*

#### Regulations on Environmental Protection and Resource Sustainability

The import, storage, usage, dealing and disposal of batteries in Singapore are regulated under several legislation in Singapore, including but not limited to the Environmental Protection and Management Act 1999 of Singapore (the “**EPMA**”) and the Environmental Public Health Act 1987 of Singapore (the “**EPHA**”), both of which and their respective subsidiary legislation are administered by the National Environmental Agency of Singapore (the “**NEA**”).

Under the EPMA, the importation of certain specified hazardous substances requires a license prior to doing so. The storage, use of and dealing with such hazardous substances must also be carried out in a manner that protects the health and safety of all persons as well as the environment. While our batteries do not contain any hazardous substances that are regulated under the licensing regime under the EPMA, we will continue to monitor for any manufacturing changes and battery developments in the future and will apply for such licensing as may be required.

Further, the disposal of obsolete and/or spent batteries and other constituent chemical waste products (collectively, “**Battery Waste**”) are regulated under the EPMA, the EPHA and the Resource Sustainability Act 2019 of Singapore (the “**RSA**”). Under the EPMA, we are not permitted to discharge or cause to be discharged Battery Waste and other polluting matters into any drain or land without the written permission of the NEA. In addition under the EPHA, we must store Battery Waste in a proper and efficient manner so as not to create a nuisance or to cause any risk, harm or injury to persons or is likely to pollute the environment, and must dispose of Battery Waste at authorized disposal facilities. The RSA also specifically provides that Battery Waste must be disposed via a waste collector or e-waste recycler that are each licensed under the EPHA.

#### Regulations on Workplace Safety and Health

The Workplace Safety and Health Act 2006 of Singapore (the “**WSHA**”) and its subsidiary legislation regulates the safety, health and welfare of persons at work in workplaces. It applies to all workplaces in Singapore (save for certain exemptions), and generally requires employers, occupiers and other stakeholders to uphold certain safety, health and welfare standards.

Under the WSHA, we are obliged to take reasonably practicable measures to ensure the safety and health of our employees, contractors, and direct or indirect subcontractors at work, including but not limited to maintaining facilities and arrangements for their welfare at work, adequate safety measures for machinery and equipment, and ensuring that such persons are not exposed to hazards in the processing, storage, transport and/or disposal of things at the occupied premises. We are required to maintain safety and health

## [Table of Contents](#)

management systems, as well as continual monitoring for compliance. Additionally, we are required to take reasonably practicable measures to ensure that any access and/or egress points to the premises occupied by us (such as storage facilities), and all machinery, equipment or substance kept at the premises, are safe and pose no risks to the health of all persons within those premises.

### Regulations on Fire Safety

The Fire Safety Act 1993 of Singapore (the “FSA”) regulates the arrangements for fire safety, fire hazards and fire prevention in premises located in Singapore. Because some of our batteries contain lithium compounds and other flammable materials, we may be required under the FSA to obtain a license for the importation and/or transport of our batteries, as well as the storage of the batteries at storage facilities. Waste products generated from the Property that are deemed as flammable material must also be disposed in accordance with the storage license granted by the relevant authorities. We will apply for such license, if required, at a later time when such batteries are imported and/or transported in Singapore.

### *Australia*

The Australian Federal Government established the CER by virtue of the Clean Energy Regulator Act 2011 and Carbon Credits (Carbon Farming Initiative) Act 2011. The CER is the regulatory authority responsible for the determination of rules in relation to carbon abatement, administration of the ERF and engaging in government purchasing of emissions reduction. The carbon abatement project is solely governed by the Australian Federal Government.

The ERF was established by virtue of the Carbon Credits (Carbon Farming Initiative) Act 2011 and the Carbon Credits (Carbon Farming Initiative) Rule 2015. The CER administers the ERF by way of funding registered ACCUs. Registered proprietors of land and registered proponents are able to create value by exploiting existing land, reducing their carbon emissions or removing and storing carbon in vegetation and/or soil.

Eligible projects may earn one ACCU for every ton of emissions reduced, avoided, removed or stored.

The CER is the primary market for ACCU sales. Carbon credits can be sold to government contracts or via secondary market, which includes private speculation, private carbon commitments or to other proponents for their respective projects. There is currently no exchange for carbon credits to be traded. Australia is introducing the Australian Carbon Exchange (“ACE”) which will facilitate the purchase, sale and settlement of ACCUs. Whether the ACE will integrate with international markets is yet to be determined.

ACCUs are purchased and sold via the Australian National Registry of Emission Units (“ANREU”) with each unit being recorded on the registry. The ANREU is governed by the Australian National Registry of Emissions Units Act 2011 and the Australian National Registry of Emissions Units Regulations 2011.

The registry monitors credits owned, transferred for income, cancelled or relinquished. Each registered proponent under the CER is required to be registered with the ANREU. Upon a successful application to the CER, the credits will be issued to the registered proponents registry account and be available for trading.

Australia is a party to the Indo-Pacific Carbon Offsets Scheme, which allows for credits obtained via carbon abatement projects to be openly traded between companies in the private sector.

### *PNG*

The current state of the laws and regulations regarding carbon credits and a carbon market in PNG is in a development phase and as such, lawmakers are having difficulties with forming the appropriate regulatory bodies and framework to ensure compliance with the Paris Agreement and its own constitution. The current regulation being Climate Change (Management) (Carbon Market) Regulation 2022 covers the rights to the carbon stored in PNG’s forests.

PNG currently has no compliant carbon market established. Given the developmental phase of the carbon market industry in PNG, there is a lack of legislation, policy framework and administrative agreements to participate domestically and internationally. PNG has created development authorization bodies to facilitate climate issues, inclusive of a carbon market. Currently, there is a moratorium on voluntary carbon contracts in PNG, due to further regulations being developed. Once the regulations are finalized, the voluntary carbon market will resume.

PNG is a party to the Indo-Pacific Carbon Offsets Scheme, which allows for credits obtained via carbon abatement projects to be openly traded between companies in the private sector.

## **Intellectual Property and Technology**

All of our current intellectual properties and technologies are exclusively licensed in from our majority shareholder, 3DOM Alliance, pursuant to a license-in agreement dated November 22, 2022. See “— *Relationship with 3DOM Alliance*” for more details.



## [Table of Contents](#)

These licensed-in intellectual property rights include five registered patent in Japan, the United States and South Korea. We also have 42 patents under application, five of which are under Patent Cooperation Treaty (“PCT”) application, with the remaining 37 patents under application in Japan, Singapore, European Patent Office, China, the United States, South Korea, Thailand and Taiwan. The licensed-in intellectual property rights also include four registered trademarks in Japan, two registered trademarks in Singapore, one trademark under application in Japan, one trademark under application in Singapore, and two trademarks under application in India. Our licensed intellectual property rights and technologies are mainly for battery cascade use, battery management system, battery cell and pack module, leasing with carbon credit, battery unit, degradation-based billing prediction, and degradation-based billing forecasting.

We protect our know-how, trade secrets and other confidential business information of any type by requiring our contractors, clients and others who develop intellectual property (including confidential information) in the course of their work for us.

### **Customers**

We currently do not have any customers as we have yet to commercialize our leasing services and other services. Our business primarily targets commercial transportation companies as well as renewable power plants and other power plants requiring grid-stabilization and backup power, that have environmental concerns, sustainability goals, and zero-emission mission. Based on our estimates of the market conditions and our operation status, we expect to commence our leasing business in the fourth quarter of 2024.

Current clients of our carbon abatement solutions business are primarily landowners in Australia and PNG.

### **Competition**

#### *Battery and Energy Storage Industry*

The battery and energy storage industry is highly competitive, and new regulatory requirements for vehicle emissions, technological advances, and shifting customer demands are causing the industry to evolve towards zero-emission solutions. We believe that the primary competitive factors in the market include, but are not limited to:

- total cost of ownership (“TCO”);
- safety, reliability and quality;
- gravimetric and volumetric energy density;
- product performance and uptime;
- charging characteristics;
- technological innovation;
- comprehensive solution from a single provider;
- ease of integration; and
- service options.

Similar to traditional OEMs in the passenger vehicle market, incumbent commercial transportation OEMs are burdened with legacy systems and the need to generate sufficient return on existing infrastructure, which has created a reluctance to embrace new zero-emission drivetrain technology. This reluctance creates opportunity for us and has allowed us to gain a significant head start against our competition. We believe the global push for lower emissions combined with vast technological improvements in fuel cell and battery-electric powertrain technologies have awakened well-established battery technology companies and vehicle manufacturers to begin investing in zero-emission transportation. We expect an accelerating transition from ICE vehicle to BEVs in the commercial transportation sector in the next three years.

Our key competitors are leading battery technology companies. Our batteries have various advantageous features, including heat resistance, higher energy density, high charge rates, high discharge rates, long lifespan and improved reliability, which are suited for different needs and operating conditions and we believe will increase our market shares. For more details, see “— *Our Competitive Strengths*” and “— *Sales and Marketing*.”

#### *Carbon Abatement Solutions and Carbon Credit Market*

In addition, we are also generating and providing carbon credits to companies who are under the pressure to decarbonize their business operations, such as logistics companies. See “— *Carbon Abatement Solutions and Carbon Credit Sales*” for more details.



## [Table of Contents](#)

### **Partnerships**

We are currently in negotiation to formalize several strategic partnerships, mainly with automakers and battery manufacturers, to seek for more mutually beneficial business opportunities.

#### ***B-ON***

We entered into an LOI with B-ON, an electric light commercial vehicles and fleet electrification service provider headquartered in Japan, on November 18, 2022. We aim to collaborate on a wide array of battery and energy businesses, including the sales of vehicles, battery cells, commercial car lease with offsetting carbon credits, fleet management and telematics, and charging and energy management. Possible business cooperation models include (i) B-ON will supply us their 4-wheeled and 3-wheeled EVs and will explore technological possibilities to employ our battery cell for their products; and (ii) we will offer carbon credits to B-ON and B-ON will license us the fleet management solutions and software for charging and energy management. As of the date of this Report, we are developing partnering plans with B-ON to engage in leasing of 3- and 4-wheeler EVs in Indonesia, Philippines and Thailand.

#### ***A Plastic Product Manufacturer***

We entered into an MOU with a Taiwanese company which principally engages in the manufacture and sales of plastic products, electronic products and polyester products, and 3DOM Alliance on January 1, 2022. By signing this MOU, we aim to form various arrangements including, among others, (i) the plastic product manufacturer to supply us with its battery materials for the mass production of our batteries and separators; (ii) to collaborate with third parties for the supply and development of battery materials towards the manufacturing of battery cells; (iii) to jointly develop a battery cell incorporating both parties' technologies; (iv) to develop and commercialize business models based upon the primary and secondary usage of batteries; and (v) to collaborate in mass production of 3DOM separator. The current MOU has been extended to December 31, 2023, unless earlier terminated by mutual agreement or by thirty (30) days' prior written notice by either party to the other party.

#### ***An Energy Solution Company***

We entered into an LOI with a well-known energy solution company headquartered in South Korea on September 15, 2022. By signing this LOI, we intend to engage with such company for the supply of its battery packs for our carbon neutral battery lease services. In addition, we also intend to source charging and swap stations from such company and/or engage it for the production of our battery cells and packs.

#### ***Assemble Point***

We entered into an MOU with 3DOM Alliance and Assemblepoint Co. Ltd. ("**Assemble Point**"), a Japanese EV maker, on December 28, 2022. By signing this MOU, we aim to jointly develop electric mini buses and batteries for such electric mini buses, and jointly provide battery-related services and carbon-free leasing services in the Philippines. The MOU will expire on December 27, 2023 and can be renewed by written agreement, unless earlier terminated (i) by the non-defaulting party upon the violation of the MOU without timely correction or (ii) by either party in the event of the commencement of insolvency proceedings against the other party.

#### ***Kyushu Sanko Bus***

We entered into an MOU with Kyushu Sanko Bus Co. Ltd., Sanko Bus Co. Ltd., and Kyushu Sanko Auto Service Co. Ltd. (collectively, "**Kyushu Sanko Bus**"), a bus operators in Japan, Freet Co. Ltd. and BINEX Inc. on December 20, 2022. By signing this MOU, we aim to provide carbon credits and leasing services along with carbon credits for the decarbonization of Kyushu Sanko buses operating in Kyushu region of Japan. We intend to conduct a proof of concept on a fuel cell bus in 2025. The MOU will expire on December 19, 2023 and can be renewed by written agreement, unless earlier terminated (i) by the non-defaulting party upon the violation of the MOU without timely correction or (ii) by either party in the event of the commencement of insolvency proceedings against the other party.

### **Suppliers and Manufacturing**

Our suppliers consist primarily of (i) raw battery material suppliers and (ii) OEMs that manufacture separators, battery cells and packs, and BEVs. We are in the process of establishing business relationships with several OEM automakers and vendors of battery materials. In addition to purchasing products from our suppliers, we plan to establish collaborative partnerships with them, particularly those OEMs. We also plan to work closely with suppliers to jointly develop advanced battery materials to create battery cells.

## [Table of Contents](#)

### **Sales and Marketing**

Equipped with the licensed-in technology and deep understanding of the Southeast Asia and South Asia markets, we take an insight-driven, strategic approach to our go-to-market strategy. Sales activities will be generally carried out by our full-time employees in our business development department. We are also establishing strategic partnerships with various automakers to have our batteries incorporated into their vehicles in order to capture more attention in the market.

We customize different marketing strategies for different customer types or regions, based on factors that are peculiar to their specific requirements for batteries. For example, we develop and market batteries with high viscosity electrolyte, in order to supply batteries that are highly reliable and enduring in regions where high operating temperature is an issue. For applications requiring high torque batteries, such as drones and sports cars, we adopt the X-SEPA multi-layer separators to develop high C discharge rate batteries that will not deteriorate. For the ESS market, we strategically focus on developing long-life batteries that can last up to 6,000 cycles to reduce our clients' costs. With respect to our business of carbon abatement solutions and carbon credit sales, we secure contracts with more landowners by offering a higher percentage share of the revenue generated from carbon credit sales. In addition, we also demonstrate expertise, industry knowledge, high standards of integrity and strong relationship with the regulators.

The head of our business development team works in close consultation with our chief product officer and chief strategy officer to develop effective strategies to market our products and services to potential customers and collaborative or joint venture partners. In particular, we place a high priority on our decarbonization life cycle assessment, which we believe will help us to win more market share of the BEV and ESS market globally in the long run. Our chief operation officer is also working with the business development team to ensure that marketing and communications efforts and programs undertaken are consistent and provide meaningful assistance.

We plan to have an effective after-sales service policy in place once we begin our battery leasing business. We plan to bear the maintenance and repair costs of our batteries and our leased BEVs and ESS. To avoid disruption to our clients' operations caused by the defects of our batteries, a spare inventory is maintained in order to replace the malfunctioning BEVs or ESS quickly.

### **Research and Development**

We do not operate or have any R&D department. Our success depends in part on the innovative and advanced technologies generated by 3DOM Alliance's R&D department.

The primary areas of focus for 3 DOM Alliance's R&D include, but are not limited to, X-SEPA multi-layer separators for high torque batteries, large lithium-ion battery prototypes, next-generation lithium metal anode, solid electrolyte rechargeable batteries, and phosphoric acid fuel cells (PAFC). 3DOM Alliance undertakes significant testing and validation of the battery products before supplying to us in order to meet our internal quality control standards and the demands of our clients.

### **Environmental Matters**

We recognize that large-scale global adoption of lithium-ion batteries will require cost-effective recycling processes. Accordingly, we focus on the use of the X-SEPA battery separator, which can double the lifespan of traditional batteries, so that our battery packs can have a "second life" as refurbished batteries or for use in stationary storage application.

In addition, our carbon abatement solutions business can help us reduce the carbon emission we generated in the process of our operations. We will use the carbon credit we earn during our carbon abatement projects to offset our own carbon emission. We believe our technologies, collaboration with waste recycling leaders, as well as our carbon abatement solutions business will help us contribute more to making a better environment.

### **Data Services and Protection**

#### ***Data Services***

Our own-and-lease business model provides an opportunity for us to accumulate a tremendous amount of raw data. We plan to build a data infrastructure by storing, managing and analyzing our data assets. This data infrastructure is expected to produce meaningful data on battery usage and behavior for the purpose of developing increasingly efficient batteries, as well as process data for intelligent and optimized transportation. We plan to utilize our smart battery infrastructure to provide data services along with our leasing services.

## [Table of Contents](#)

### **Data Protection**

We have established data access rights for each department and data file, and have appointed a management personnel to control such data access rights. While we have yet to establish a data protection policy, an information security committee have been set up to look into the following:

- the establishment of information management rules and guidelines, such as manner of classification of confidential information, establishment of confidential information storage locations, and documentation of intangible assets;
- establishing and strengthening information security infrastructure; and
- providing information security education for company personnel.

### **C. Organizational Structure**

Upon consummation of the Business Combination, noco-noco Pte. Ltd., PNAC and New SubCo became wholly-owned subsidiaries of the Company. The following diagram depicts a simplified organizational structure of the Company as of the date hereof. These subsidiaries are also set forth in Exhibit 8.1 to this Report.

Name	Jurisdiction	% of Ownership Interest Held by the Company
noco-noco Australia Pty Ltd.	Australia	52%

\* Other subsidiaries of the Company, including PNAC, have been omitted because, in the aggregate, they would not be a “significant subsidiary” as defined in rule 1-02(w) of Regulation S-X as of the completion of the Business Combination.

### **D. Property, Plants and Equipment**

Our registered office is at 89 Nexus Way, Camana Bay, Grand Cayman, KY1-9009, Cayman Islands, and our principal executive office is 4 Shenton Way, #04-06 SGX Centre II, Singapore 068807, with a total area of 2,432 square feet. The lease will expire on September 14, 2024.

### **ITEM 4A. UNRESOLVED STAFF COMMENTS**

None.

### **ITEM 5. OPERATING AND FINANCIAL REVIEW AND PROSPECTS**

#### **A. Operating Results**

*You should read the following discussion and analysis of our financial condition and results of operations in conjunction with our consolidated financial statements and the related notes included elsewhere in this Report. This discussion contains forward-looking statements that involve risks and uncertainties about our business and operations. Our actual results and the timing of selected events may differ materially from those anticipated in these forward-looking statements as a result of various factors, including those we describe under “Item 3. Key Information — D. Risk Factors” and elsewhere in this Report.*

#### **Recent Developments**

Recent events impacting our business are as follows:

#### **Business Combination**

We consummated the Business Combination on August 25, 2023. Our Ordinary Shares and Warrants commenced trading on the Nasdaq on August 28, 2023, under the symbols “NCNC” and “NCNCW”, respectively.

#### **Key Factors Affecting Our Business**

As a pre-commercialization stage company, we believe that our performance and future success depend on several factors that present significant opportunities for us but also pose significant risks and challenges, including those discussed below and in the section titled “Item 3. Key Information — D. Risk Factors” in this Report.

#### **Continued Development and Upgrade of Our Battery Products**

We license in a series of state-of-the-art patents and know-how technologies from 3DOM Alliance, our majority shareholder, with respect to, among others, battery cascade use, battery management system, battery cell and pack model, and battery units. For

## [Table of Contents](#)

details of our licensing-in arrangement with 3DOM Alliance, see the section entitled “Item 4. Business Overview — Relationship with 3DOM Alliance” in this Report. These licensed-in technologies enable us to produce batteries that we believe, as compared to conventional batteries, are designed to have a longer lifespan and higher reliability, and be more resistant to high operating temperature and thermal runaways. Therefore, our ability to produce state-of-the-art battery products and achieve profitability in our leasing services depends, in part, on the continued innovation of the technologies licensed-in from 3DOM Alliance.

### ***Partnering with Industry-Leading Automakers and Manufacturers***

We have entered into several MOUs with our strategic partners, including well-known automakers and battery manufacturers, for potential business collaborations and formation of strategic joint ventures. See the section entitled “Item 4. Business Overview — Partnerships” in this Report. We believe that our battery products will experience swift market adoption due to our strategic partnerships with these automakers and manufacturers. We plan to collaborate with other automakers and OEMs to expedite such adoption and increase market acceptance of our battery products over time.

### ***Our ability to procure new contracts with landowners***

The key factor driving the demand for carbon credits is the global push towards decarbonization, driven by governmental and supra national bodies, such as the United Nations. As more and more nations start to adopt or even accelerate the setting of standards for compliance towards zero carbon emissions, the demand for carbon credits is anticipated to surge. Carbon credit prices have been in an uptrend since 2007 and, aside from minor short-term fluctuations, are likely to continue the long-term uptrend. This will mean higher earnings from our carbon credit sales. Therefore, our ability to procure and sign new contracts with landowners to increase credits generations is highly dependent on our reputation and expertise in this industry. As such, our business is subject to adverse events which may cause damage, whether real or perceived, to our reputation. For more information, see the section entitled “Item 3. Key Information — D. Risk Factors — Risks Related to Our Business and Industry” in this Report.

### ***Competition***

The battery and BEV market is fast-growing, competitive and driven by the innovation of both large companies and emerging entrants like us. We acknowledge that the existing market players and other emerging entrants may have greater resources to invest in advancing their technologies, access to more potential customers, or strategic relationships with OEMs (or other third parties) that may give them a competitive edge. We further acknowledge that these disparities, where they exist, have the potential to harm our business, results of operations or financial condition.

### ***Capital Needs***

We have incurred net loss and negative cash flows from operations for the years ended June 30, 2023 and 2022, respectively. Assuming we experience no significant delays in the commercialization of our business, we believe that our cash resources are sufficient to fund our marketing activities and manufacturing of battery products through OEMs. For more information, see “— Liquidity and Capital Resources.”

### ***Government Regulatory and Compliance***

There are government regulations pertaining to battery safety, transportation of batteries, use of batteries in vehicles, product liabilities and disposal of hazardous materials. We will ultimately have to comply with these regulations to lease our battery products. In addition, changes in national or global regulations may affect the demand for credits or our ability to generate credits. Hence, we are constantly keeping abreast of current or potential changes in regulations, and where possible, engage with the regulators in order to understand or anticipate potential headwinds that may affect our business. See the section entitled “Item 3. Key Information — D. Risk Factors — Risks Related to Our Business and Industry” in this Report for the risks that may affect our business, and “— Government Regulations” for details of the regulations that are applicable to our business operations.

### ***Basis of Presentation***

Our financial statements have been prepared in conformity with U.S. GAAP in U.S. dollars. For more information about our basis of presentation, refer to Note 3 to our accompanying audited financial statements as of and for the years ended June 30, 2023 and 2022.

### ***Significant Accounting Policies and Estimates***

#### ***Cash and Cash Equivalents***

Cash and cash equivalents consist of cash on hand and demand deposit with banks, which are unrestricted as to withdrawal and use, and which have original maturities of three months or less when purchased.



## [Table of Contents](#)

### ***Deposit, Upfront Payment and Other Receivables***

Security deposits paid for office lease are accounted for as deposits. Amounts paid in advance for future expenses are accounted for as prepaid expenses. Goods and service tax refunds are accounted for as other receivables. We expect that the result of adopting current expected credit loss model (“CECL”) is immaterial to other receivables.

### ***Property and equipment***

Property and equipment are stated at cost, less accumulated depreciation. Expenditures for additions, major renewals and betterments are capitalized and expenditures for maintenance and repairs are charged to expense as incurred.

Depreciation is computed using the straight-line method over the estimated useful lives of the related capitalized assets. The estimated useful lives are as follows:

	<u>Useful lives</u>
Office equipment	5 years

### ***Other Current Liabilities***

Other current liabilities are liabilities for goods and services provided to us prior to the end of the financial year which are unpaid. They are classified as current liabilities if payment is due within one year or less. If not, they are presented as non-current liabilities.

### ***Deferred Tax Asset Allowance***

Deferred tax assets are recognized for tax losses not yet used and temporary deductible differences. As those deferred tax assets can only be recognized to the extent that it is probable that future taxable profit will be available against which the unused tax credits can be utilized, management’s judgement is required to assess the probability of future taxable profits. Management’s assessment is constantly reviewed and additional deferred tax assets are recognized if it becomes probable that future taxable profits will allow the deferred tax asset to be recovered.

### ***Share-based compensation transaction***

The Company measures the cost of equity-settled transactions by reference to the fair value of the equity instruments at the date at which they are granted. Estimating fair value for share-based compensation transactions requires determining the most appropriate valuation model, which is dependent on the terms and conditions of the grant. This estimate also requires determining the most appropriate inputs to the valuation model including the expected life of the stock option, volatility and dividend yield and making assumptions about them. The fair value of the ordinary shares was determined by obtaining quoted prices over-the-counter market based on the latest transacted price of the Company shares that were sold.

### ***Leases***

We have entered into operating lease agreements primarily for office. We determine if an arrangement is a lease at inception. For all classes of underlying assets, we elect not to recognize right of use assets or lease liabilities when a lease has a lease term of 12 months or less at the commencement date and does not include an option to purchase the underlying asset that we are reasonably certain to exercise.

Operating lease assets and liabilities are recognized at the present value of the future lease payments at the lease commencement date. The interest rate used to determine the present value of the future lease payments is our incremental borrowing rate, because the interest rate implicit in most of our leases is not readily determinable. Our incremental borrowing rate is estimated to approximate the interest rate on a collateralized basis with similar terms and payments, and in economic environments where the leased asset is located. Operating lease assets also include any prepaid lease payments and lease incentives. Our lease terms include periods under options to extend or terminate the lease when it is reasonably certain that we will exercise that option. We generally use the base, non-cancellable, lease term when determining the lease assets and liabilities. Operating lease expense is recognized on a straight-line basis over the lease term.

### ***Comparative Information***

Certain items in prior years consolidated financial statements have been reclassified to conform to the current period’s presentation to facilitate comparison.



## **Recent Accounting Pronouncements**

In June 2016, the Financial Accounting Standards Board (the “FASB”) issued Accounting Standard Update No. 2016-13, Financial Instruments — Credit Losses (Topic 326), Measurement of Credit Losses on Financial Instruments. This standard requires a financial asset (or group of financial assets) measured at amortized cost basis to be presented at the net amount expected to be collected. The allowance for credit losses is a valuation account that is deducted from the amortized cost basis of the financial asset(s) to present the net carrying value at the amount expected to be collected on the financial asset. We adopted the new standard effective January 1, 2023 and the adoption of this guidance did not have a material impact on our financial statements.

In December 2019, the FASB issued Accounting Standard Update No. 2019-12, Income Taxes (Topic 740): Simplifying the Accounting for Income Taxes (ASU 2019-12), which simplifies the accounting for income taxes. This guidance became effective for entities for the fiscal years, and interim periods within those fiscal years, beginning after December 15, 2020 on a prospective basis, with early adoption permitted. We adopted the new standard effective January 1, 2021 and the adoption of this guidance did not have a material impact on our financial statements.

We do not expect any other recently issued accounting standards to have a material impact on our financial position, results of operations or cash flows when they become effective.

## **Components of Results of Operations**

We are an early-stage growth company in the pre-commercialization stage of development. We have not generated any revenue from sales to customers, and our historical results may not be indicative of our future results for reasons that may be difficult to anticipate. Our ability in the future to generate revenue sufficient to achieve profitability will depend largely on the successful development of our battery products as well as the commercialization of our own-and-lease business model and our carbon abatement solution business. Accordingly, the drivers of our future financial results, as well as the components of such results, may not be comparable to our historical results of operations.

### ***Operating expenses***

Our operating expenses primarily consist selling, general and administrative expenses. Our selling, general and administrative expenses consist primarily of stock-based compensation, directors’ remuneration, payroll and related cost, expenses incurred for depreciation of office equipment, and costs incurred for outside contractor and professional service fees, audit and compliance expenses, legal, accounting and other advisory services. For the years ended June 30, 2023 and 2022, we incurred total operating expenses of \$16.8 million and \$1.1 million, respectively.

We are rapidly expanding our personnel headcount, in anticipation of planning for and supporting our growth and operating as a public company. Accordingly, we expect our selling, general and administrative expenses to increase significantly in the near term and for the foreseeable future. Upon commencement of commercial operations, we also expect to incur customer and sales support and advertising expenses.

### ***Other income/(expense)***

Other income/(expense) comprises of (i) other income, including a one-off sale of batteries to a business partner and COVID-19 government grant, (ii) other expense, including costs incurred from the one-off sale of batteries, and (iii) foreign exchange gain. For the years ended June 30, 2023 and 2022, we generated total other income of \$49,084 and \$11,828, respectively.

## [Table of Contents](#)

### **Results of Operations**

The following table sets forth a summary of our results of operations for the periods indicated.

	For the Years Ended June 30,	
	2023	2022
<b>Operating expenses:</b>		
Research and development	\$ —	\$ 137,412
Selling, general and administrative expenses	16,840,854	951,239
<b>Total operating expenses</b>	<b>16,840,854</b>	<b>1,088,651</b>
<b>Loss from operations</b>	<b>(16,840,854 )</b>	<b>(1,088,651 )</b>
<b>Other income/(expense):</b>		
Other income	36,439	11,792
Other expense	(256)	—
Foreign exchange gain	12,901	36
<b>Total other income</b>	<b>49,084</b>	<b>11,828</b>
<b>Net loss</b>	<b>\$ (16,791,770 )</b>	<b>\$ (1,076,823 )</b>

### **Comparison of Years Ended June 30, 2023 and 2022**

**Operating expenses.** Total operating expenses increased by 1,447% to \$16.8 million for the year ended June 30, 2023 from \$1.1 million for the year ended June 30, 2022. The increase was primarily due to (i) an increase in selling, general and administrative expenses of \$15.9 million, which was attributable to an increase in payroll and related cost associated with the hiring of new employees, and stock-based compensations for services relating to carbon credit expertise.

**Other income/(expense).** Total other income increased by 315% to \$49,084 for the year ended June 30, 2023 from \$11,828 for the year ended June 30, 2022. Such increase was primarily because (i) we received an increase in government working labor relief of \$36,439, and (ii) exchanges gains of S\$12,901.

**Net loss.** As a result of the foregoing, our net loss increased by 1,459% to \$16.8 million for the year ended June 30, 2023 from \$1.1 million for the year ended June 30, 2022.

### **B. Liquidity and Capital Resources**

Historically, our principal sources of liquidity have been financing transactions with investors and loans from our majority shareholder that have provided us with the necessary funds to support our business activities. As of June 30, 2023, we had raised approximately \$1.5 million of funding through the issuance of ordinary shares. On August 1, 2020, we issued a promissory note with 3DOM Alliance (the “Note”). The Note provides for borrowings upon our request, on one or more occasions, up to an aggregate of principal amount of S\$8.0 million (\$5.8 million). No interest shall accrue to any loans under the Note. As of June 30, 2023, we had drawn down an aggregate amount of S\$4.8 million (\$3.6 million).

On November 22, 2022, we entered into an exclusive, irrevocable license-in agreement with 3DOM Alliance, pursuant to which we are obligated to pay a one-off, refundable upfront payment of \$30 million licensing fee to 3DOM Alliance. In addition, we shall pay quarterly royalties equal to three percent (3%) of the gross profit generated using each of 3DOM IP Rights granted to us, including its proprietary and licensed-in patents and other intellectual property, as well as confidential yet critical know-how and other information. Such upfront payment shall be credited against any royalties under the agreement such that the amount of the upfront payment shall be deducted from the royalties when due and payable. In the event that the upfront payment has any remaining amount after the last deduction from the royalties at the end of a five-year period from the last instalment of the upfront payment, the remaining unutilized amount shall be refunded to us at our request. Pursuant to a supplemental agreement to the license-in agreement dated May 10, 2023 (the “Supplemental Agreement”), the upfront payment shall be payable over a series of instalments after the consummation of the Business Combination, in such amounts and pursuant to such repayment schedule as may be agreed between 3DOM Alliance and us. Both parties shall negotiate the installment plan in good faith, taking into consideration our working capital needs as well as our liquidity and available capital resources after the consummation of the Business Combination. As a result, we do

not expect that the \$30 million upfront payment will have a material impact on our liquidity and capital resources before or after the consummation of the Business Combination. As of the date of this Report, we had not paid any upfront payments to 3DOM Alliance yet. See “noco-noco’s Business — Relationship with 3DOM Alliance” and “Certain Relationships and Related Person Transactions — noco-noco and Pubco Relationships and Related Party Transactions — License-in Agreement.”

## [Table of Contents](#)

On August 14, 2023, we entered into a purchase agreement with Arena Business Solutions Global SPC II, Ltd. (“Arena”) as amended from time to time, (the “Purchase Agreement”), pursuant to which, we have the right to sell to Arena up to \$150,000,000 of our Ordinary Shares, subject to certain limitations and conditions set forth in the Purchase Agreement, from time to time during the 36-month term of the Purchase Agreement. Sales of our Ordinary Shares pursuant to the Purchase Agreement, and the timing of any sales, are solely and exclusively at our option, and we are under no obligation to sell any securities to Arena under the Purchase Agreement.

As of June 30, 2023, we had cash and cash equivalents of \$17,789. Our cash and cash equivalents are primarily denominated in Singapore dollars as well as in local currencies of our Priority Markets. We have yet to generate any revenue from our business operations, and we have not achieved profitable operations or positive cash flows from our operations since inception. Our accumulated deficit aggregated \$19.1 million as of June 30, 2023 and we expect to incur substantial losses in future periods. As an early-stage growth company in the pre-commercialization stage of development, the net loss we have incurred since inception are consistent with our strategy and budget.

We plan to finance our operations with a combination of proceeds from the Business Combination, capital from investors and shareholders, and if required in the future, loans from financial institutions, as well as anticipated future revenue from our service offerings. Our ability to successfully develop our products, commence commercial operations and expand our business will depend on many factors, including our working capital needs, the availability of equity and/or debt financing and, over time, our ability to generate positive cash flows from operations.

Due to the capital-intensive nature of our business, we expect to sustain substantial operating expenses, without generating sufficient revenues, to cover expenditures for a number of years. Over time, we expect that we will need to raise additional funds through a variety of possible methods, including, but not limited to, entry into joint ventures or other strategic arrangements, the issuance of equity, equity-related or debt securities or through obtaining credit from financial institutions. These funds are expected to finance our principal sources of liquidity and ongoing operating expenses. If we were to require additional funding or otherwise determined it was beneficial to seek additional sources of financing or enter into other arrangements as described above, we believe that our debt-free balance sheet would enable us to access financing on reasonable terms. However, there can be no assurance that such additional capital would be available on attractive terms, if at all, when needed, which could be dilutive to stockholders. We may be forced to decrease our level of investment in product development or scale back our operations. Furthermore, the cost of debt could be higher than anticipated. There can also be no assurance that positive cash flow from operations can be achieved or sustained. See “Item 3. Key Information — D. Risk Factors — Risks Related to Our Business and Industry — We may need to raise additional funds and these funds may not be available to us when we need them. If we cannot raise additional funds when we need them, our business, prospects, financial condition and operating results could be negatively affected.”

There is no assurance that the plans will be successfully implemented. If the we fail to achieve these goals, we may need additional financing to repay debt obligations and execute our business plan, and we may not be able to obtain the necessary additional capital on a timely basis, on acceptable terms, or at all. In the event that financing sources are not available, or that we are unsuccessful in increasing our gross profit margin and reducing operating losses, we may be unable to implement our current plans for expansion, repay debt obligations or respond to competitive pressures, any of which would have a material adverse effect on our business, financial condition and results of operations and may materially adversely affect our ability to continue as a going concern. See “Item 3. Key Information--D. Risk Factors--Risks Related to Our Business and Industry--The consolidated financial statements accompanying this Report contain disclosures related to our ability to continue as a going concern.”

Our financial statements do not include any adjustments related to the recoverability and classification of recorded assets or the amounts and classification of liabilities or any other adjustments that might be necessary should we be unable to continue as a going concern.

Our financial statements have been prepared on a going concern basis, which contemplates the realization of assets and the satisfaction of liabilities in the normal course of business. The realization of assets and the satisfaction of liabilities in the normal course of business are dependent on, among other things, our ability to operate profitably, to generate cash flows from operations, and to pursue financing arrangements to support our working capital requirements.

### ***Working Capital/(Deficit)***

	As of June 30,		Changes	%
	2023	2022		
Current assets	\$ 455,943	\$ 183,889	\$ 272,054	148%
Current liabilities	760,391	49,612	710,779	1433%
Working capital deficit	\$ (304,448 )	\$ 134,277	\$ (438,725 )	(327)%

Our cash and cash equivalents amounted \$17,789 and \$81,626 as of June 30, 2023 and 2022, respectively.

## [Table of Contents](#)

As of June 30, 2023, we had total liabilities of \$4.4 million, consisting of accruals and other payable of \$587,346, amount due to shareholders of \$3.6 million and current portion of operating lease liabilities of \$173,045 and non-current portion of operating lease liabilities of \$36,699.

As of June 30, 2022, we had total liabilities of \$1.0 million, which included accruals and other payable of \$13,227, amount due to shareholders \$1.0 million and current portion operating lease liabilities of \$36,385.

As of June 30, 2023, we had a working capital deficiency of \$304,448 compared with a working capital surplus of \$134,276 as of June 30, 2022.

The increase in the working capital deficiency was due to (i) an increase in accruals and other payables of \$574,199, (ii) an increase in current portion of operating lease liabilities of \$136,660, partially offset by (iii) an increase in due from promissory note of \$333,594.

### **Cash Flows**

The following table summarizes our cash flow data for the year ended June 30, 2023 and 2022.

	Year Ended June 30,		Changes	%
	2023	2022		
Cash used in operating activities	\$ (2,982,778)	\$ (805,177)	(2,177,601)	270 %
Cash used in investing activities	(5,735)	(3,888)	(1,847)	48 %
Cash generated from financing activities	3,388,587	873,066	2,515,521	288 %
Increase/(decrease) in cash and cash equivalents	400,074	64,001	336,073	525 %

#### *Cash used in operating activities*

Net cash used in operating activities for the year ended June 30, 2023 was \$3.0 million, while our net loss for the same year was \$16.8 million. The difference was primarily due to (i) adjustments for non-cash items including depreciation expense of \$4,855, stock-based compensation of \$13,568,137, loss on disposal of property and equipment of \$256 and changes in working capital including (ii) an increase in due from promissory note of \$333,594, (iii) an increase in deposits and prepayments of \$2,805, and (iv) a decrease in operating lease liabilities of \$1,976, partially offset by (v) an increase in accruals and other payables of \$574,119.

Net cash used in operating activities for the year ended June 30, 2022 was \$0.8 million, while our net loss for the same year was \$1.1 million. The difference was primarily due to (i) adjustments for non-cash items including depreciation expense of \$3,447, and changes in working capital including (ii) a decrease in inventory of \$163,259, (iii) an increase in accruals and other payables of \$121,253, and (iv) an increase in operating lease liabilities of \$2,565, partially offset by (v) an increase in deposit, upfront payments and other receivables of \$18,878.

#### *Cash used in investing activities*

Net cash used in investing activities for the year ended June 30, 2023 was \$5,735, primarily comprising of purchase of computers. Net cash used in investing activities for the year ended June 30, 2022 was \$3,888, primarily comprising of purchase of computers.

#### *Cash generated from financing activities*

Net cash generated from financing activities primarily consisted of advances from 3DOM Alliance, amounting to \$3.4 million and \$0.9 million for the years ended June 30, 2023 and 2022, respectively.

### **Capital Expenditures**

Our capital expenditures amounted to \$8,888 for the year ended June 30, 2023. These capital expenditures primarily related to the purchase of computers. We expect to continue to make capital expenditures to meet the expected growth in scale of our business and expect that cash generated from our cash and cash equivalents following the Business Combination and cash from operating activities and financing activities may be used to meet our capital expenditure needs in the foreseeable future.

### **Off-Balance Sheet Commitments and Arrangements**



As of June 30, 2023, we did not have any off-balance sheet arrangements, as defined in the rules and regulations of the SEC, that have or are reasonably likely to have a current or future effect on our financial condition, changes in our financial condition, revenue, or expenses, results of operations, liquidity, capital expenditures, or capital resources that are material to investors.

## [Table of Contents](#)

### Emerging Growth Company Status

We are an “emerging growth company,” as defined in the JOBS Act, and we may take advantage of reduced reporting requirements that are otherwise applicable to public companies. Section 107 of the JOBS Act exempts emerging growth companies from being required to comply with new or revised financial accounting standards until private companies are required to comply with those standards. The JOBS Act also exempts us from having to provide an auditor attestation of internal control over financial reporting under Sarbanes-Oxley Act Section 404(b).

### Holding Company Structure

noco-noco Inc. is an exempted company with limited liability incorporated in the Cayman Islands on December 28, 2022 with no material operations of its own. We currently conduct our operations primarily through our subsidiaries. As a result, our ability to pay dividends primarily depends upon dividends paid by our subsidiaries. If our existing subsidiaries or any newly formed ones incur debt on their own behalf in the future, the instruments governing their debt may restrict their ability to pay dividends to us.

### C. Research and Development, Patents and Licenses

We do not operate or have any R&D department. Our success depends in part on the innovative and advanced technologies generated by 3DOM Alliance’s R&D department.

The primary areas of focus for 3 DOM Alliance’s R&D include, but are not limited to, X-SEPA multi-layer separators for high torque batteries, large lithium-ion battery prototypes, next-generation lithium metal anode, solid electrolyte rechargeable batteries, and phosphoric acid fuel cells (PAFC). 3DOM Alliance undertakes significant testing and validation of the battery products before supplying to us in order to meet our internal quality control standards and the demands of our clients.

All of our current intellectual properties and technologies are exclusively licensed in from our majority shareholder, 3DOM Alliance, pursuant to a license-in agreement dated November 22, 2022. See “— *Relationship with 3DOM Alliance*” for more details.

These licensed-in intellectual property rights include five registered patent in Japan, the United States and South Korea. We also have 42 patents under application, five of which are under Patent Cooperation Treaty (“PCT”) application, with the remaining 37 patents under application in Japan, Singapore, European Patent Office, China, the United States, South Korea, Thailand and Taiwan. The licensed-in intellectual property rights also include four registered trademarks in Japan, two registered trademarks in Singapore, one trademark under application in Japan, one trademark under application in Singapore, and two trademarks under application in India. Our licensed intellectual property rights and technologies are mainly for battery cascade use, battery management system, battery cell and pack module, leasing with carbon credit, battery unit, degradation-based billing prediction, and degradation-based billing forecasting.

We protect our know-how, trade secrets and other confidential business information of any type by requiring our contractors, clients and others who develop intellectual property (including confidential information) in the course of their work for us.

### D. Trend Information

Other than as disclosed elsewhere in this annual Report, we are not aware of any trends, uncertainties, demands, commitments or events for the fiscal year ended June 30, 2023 that are reasonably likely to have a material and adverse effect on our net revenues, income, profitability, liquidity or capital resources, or that would cause the disclosed financial information to be not necessarily indicative of future results of operations or financial conditions.

### E. Critical Accounting Estimates

For our critical accounting estimates, see “Item 5. Operating and Financial Review and Prospects—A. Operating Results—Significant Accounting Policies and Estimates.”

## ITEM 6. DIRECTORS, SENIOR MANAGEMENT AND EMPLOYEES

### A. Directors and Senior Management

The following table sets forth certain information relating to our executive officers and directors as of the date of this Report. Our board of directors is comprised of six directors.

Name	Age	Position
Mr. Masataka Matsumura	43	Chief Executive Officer and Director

Ms. Mari Matsushita	47	Chief Product Officer and Director
Mr. Yuta Akakuma	38	Head of Business Development and Director
Mr. Ng Wee Kiat (Darren)	48	Chief Financial Officer

## [Table of Contents](#)

Mr. Tatsuo Mori	58	Head of Product Management
Mr. Timothy Lai Wah Teo	71	Independent Director
Mr. Heizo Takenaka	72	Independent Director
Mr. Jean-Francois Raymond Roger Minier	52	Independent Director

**Masataka Matsumura** has served as a Director on our board of directors as well as our Chief Executive Officer since August 25, 2023. He has served as noco-noco's chief executive officer, since November 2022, and a director, since October 2022. Mr. Matsumura currently also serves as the representative director and the chief executive officer of 3DOM Alliance since September 2018 where he has served as a director since November 2016. He is also a director of Tesnology Inc. since April 2020 and was a director of BINEX Inc. from May 2021 to January 2023. In addition, he is also serving as the representative director on the board of Quintuple Air Inc., Social Mobility, Inc. and FOREST PINE DESIGN LAB Inc., since November 2019, December 2018 and November 2012, respectively, and has been serving as a non-executive director of Ellebeau Inc. since June 2014. From December 2013 to February 2019, Mr. Matsumura served as a director of Future Science Research Inc., which is one of the principal shareholders of noco-noco. Prior to Future Science Research Inc., he was the creative director of Fujiwara Design Studio S.R.L., and also the representative director and the president of Steadfast Inc. from April 2005 to June 2012. Mr. Matsumura received his bachelor of fine arts degree in fashion design and marketing from American InterContinental University London.

**Mari Matsushita** has served as a Director on our board of directors since August 25, 2023. She has also been serving as the chief product officer of noco-noco since October 2022 and the general manager of the platform development team of 3DOM Alliance since April 2021. Prior to joining us, Ms. Matsushita previously worked as a product manager at Fourth Valley Concierge Corporation from March 2017 to February 2021 and at Tsuburaya Fields Holdings Inc. from October 2012 to March 2017. From January 2004 to September 2012, Ms. Matsushita was a senior web producer at IMJ Corporation, responsible for digital marketing with data analytics and web integration. She worked at DeeCorp Limited as a market researcher from August 2003 to December 2003. Prior to DeeCorp, Ms. Matsushita worked as a sales and marketing manager at JEPICO Corporation from April 1998 to July 2003. Ms. Matsushita received her bachelor of arts in international legal study from Sophia University in Japan in 1998.

**Yuta Akakuma** has served as a Director on our board of directors since August 25, 2023. Mr. Akakuma has been the head of business development of noco-noco since November 2022, where he was previously working as a business development manager from May 2022 to October 2022. In addition, Mr. Akakuma has been serving as the managing director and the chief executive officer of 3DOM (Asia) Co., Ltd., a fellow subsidiary of noco-noco, since November 2022. Prior to this, he worked as the general manager of sales and marketing department and joint venture department at Summit Auto Seats Industry from April 2019 to April 2022, during which he also served as director for several subsidiaries of Summit Auto Seats Industry. He also worked at Darwin Summit Corporation Company Limited, as general manager from April 2019 to April 2022, and simultaneously served as the deputy chief executive officer at Faurecia and Summit Interior Systems Thailand Co., Ltd., the chief executive officer at Summit Hirofumi Sugihara Co., Ltd. and a director at Summit & Autoneum (Thailand) Co., Ltd., from June 2020 to April 2022. Prior to that, Mr. Akakuma was the deputy managing director at Soltec Thai Co., Ltd from May 2018 to April 2019. Mr. Akakuma founded Sakura Kaigo (Thailand) Co., Ltd. and served as its managing director from November 2013 to April 2018. Before that, he founded Imm & Co., Ltd. and served as managing director from May 2010 to April 2018. Prior to the founding of his own companies, he worked as the Thailand representative office manager at Agilis Inc. from October 2008 to May 2010. Mr. Akakuma received his bachelor of arts degree in environmental and information studies from Keio University in Japan in 2008.

**Ng Wee Kiat (Darren)** has served as our Chief Financial Officer since September 14, 2023. He has over two decades of leadership experiences in leading banks, fintech companies and private equity firms in Asia, responsible for financial planning and analysis, financial controlling, business transformation, strategy, operations, sales incentive management & analytics and business management. He was recognized amongst the Top 50 CFOs in Southeast Asia in 2022. Prior to joining our Company, Mr. Ng served as the chief financial officer and remains an independent non-executive director in TAKI NETWORK PTE. LTD., a global Web3 fintech company, since March 2022. Prior to that, he worked as the chief performance officer at Clermont Group, an international private equity group, from September 2020 to February 2022. He served as a director and a key member of the regional business development team under the chief operating officer office at SEA (NYSE: SE) from February 2020 to July 2020. He held the positions as the group chief financial officer of OCBC Bank, responsible for the consumer banking and wealth management division, from March 2016 to January 2020; the country head of business finance at HSBC Singapore from October 2009 to February 2016; the head of performance management for consumer, private and business banking (Singapore and Southeast Asia) at Standard Chartered Bank from April 2007 to September 2009; and a vice president of business finance managing the performance of the consumer banking operations across Asia at DBS Bank from August 2004 to April 2007. He also worked as a senior financial analyst in the Ministry of Defence of Singapore from August 2000 to August 2004, after serving as a management executive at PSA International Pte Ltd from July 1999 to August 2000. Mr. Ng received a bachelor of accountancy degree from Nanyang Technological University in Singapore in 1999.

**Tatsuo Mori** has served as noco-noco's head of product management since August 25, 2023. Mr. Mori has been serving as the manager of the Skinkoyasu office and the product division manager of 3DOM Alliance since March 2021. He has 30 years' experience in the battery business. Mr. Mori previously worked at Panasonic Holdings Corporation ("Panasonic") for more than 28 years from September 1990 to July 2020, serving as product development engineer and plant manager, responsible for overseeing the

## [Table of Contents](#)

manufacturing floor and management of the battery manufacturing plant, and then as the president of several Panasonic's subsidiaries. Prior to Panasonic, he worked at Nichicon Corporation as product development engineer from April 1987 to August 1990. Mr. Mori obtained his bachelor of science in engineering from Chuo University Faculty of Science and Engineering in Japan in 1987.

**Timothy Lai Wah Teo** has served as an Independent Director on our board of directors since August 25, 2023. He has served as an independent director of noco-noco since August 2021 and is currently serving as a director on the board of Dr Andrew Ng Global Missions Fund, School of the Arts, Singapore (SOTA) and the JurongHealth Fund (JHF). He is also currently an independent director of Pilgrim Partners (Asia) Pte. Ltd. since February 2010 and a director of Sparrow Asset Management Pte. Ltd. since August 2008. From November 2008 to October 2021, Mr. Teo served as an independent non-executive director and the chairman of the audit and risk management committee of the Singapore Exchange listed GuocoLand Limited. From April 1998 to March 2007, Mr. Teo was the director of the Government of Singapore Investment Corporation, in charge of foreign exchange, money market, gold and commodities management. Prior to this, he served as a director of Nuri Holdings Singapore from October 1994 to April 1998. Mr. Teo also worked at JP Morgan for 20 years in various overseas locations at senior management level in global markets department from May 1975 to June 1993. Mr. Teo completed his master of business administrative at Macquarie University in Sydney, Australia in July 1996.

**Heizo Takenaka** has served as an Independent Director on our board of directors since August 25, 2023. He has served as an independent director of 3DOM Alliance since June 2022. Mr. Takenaka is currently a professor emeritus at Keio University in Japan where he started as an associate professor in April 1990. He is concurrently serving as a visiting associate professor at Harvard University since January 1989 where he started as a visiting scholar in January 1981. In addition, he is also holding positions including research advisor to the Japan Center for Economic Research since December 2010 where he started as a special advisor in December 2006, chairman of the board of academyhills since December 2006, independent director of SBI Holdings, Inc. since June 2016, and member of the board of trustees of the World Economic Forum since June 2007. He was elected to the House of Councilors in July 2004, then resigned from the House of Councilors in September 2006. In April 2001, he was appointed Minister of State for Economic and Fiscal Policy in the Koizumi Cabinet, followed by appointments as Minister of State for Financial Services in September 2002, Minister of State for Privatization of Postal Services in September 2004, and Minister of Internal Affairs and Communications from October 2005 to September 2006. Prior to that, Mr. Takenaka worked at the Japan Development Bank since March 1973 to January 1981. He received a bachelor of arts in economics from Hitotsubashi University in Japan in April 1973 and a Ph.D. in economics from Osaka University in April 1994.

**Jean-Francois Raymond Roger Minier** has served as an Independent Director on our board of directors since August 25, 2023. Mr. Minier is currently serving as the Asia Pacific regional director of Audere International since April 2022, the joint representative director and co-chief executive officer of Les Rois Mages Japan Co., Ltd. since November 2021, an independent director of DKK Denki Kogyo Co., Ltd. since June 2021, an independent auditor of Amuseum Parks Co., Ltd. since April 2020, a trustee of Ueno Gakuen Educational Foundation and a representative director of ABC Properties Co., Ltd. since March 2017. He previously worked as a managing director and then a senior advisor at Kroll, LLC from April 2020 to March 2022, a corporate project director at Rusal from November 2016 to March 2020, a non-executive director and the head of corporate development in Northeast Asia of First Names Group from November 2016 to October 2017. Mr. Minier had also served as the managing director and Asia head of fund services at Moore Group Limited from November 2013 to October 2016, an advisor to the chairman for international relations at Kyoto Prefectural Union of Agricultural Cooperatives from April 2013 to August 2016, an advisor to the chief executive officer (Japan and Korea) at Buhler Group from November 2013 to December 2015. Prior to that, he worked as an Asia-Pacific advisor at Avis Partners from September 2009 to October 2013, the chief executive officer of Asia Pacific region and Tokyo branch manager at Dresdner Kleinwort from August 2006 to September 2009, managing director, Tokyo branch manager and head of capital markets in Asia Pacific at Dresdner Kleinwort Wasserstein from August 2001 to July 2006, managing director of global equities at Dresdner Kleinwort Benson from March 1998 to July 2001, head of OTC equity derivatives trading at Natwest Securities from February 1997 to February 1998. Mr. Minier also worked as a vice president and an equity derivatives trader at Morgan Stanley Japan from April 1995 to January 1997, an equity derivatives trader and structurer at Bankers Trust from December 1993 to March 1995, and an equity derivatives trader at Indosuez W.I. Carr from September 1992 to November 1993. Mr. Minier received his master of science in financial mathematics from Ecole Polytechnique in Paris, France in 1992 and completed the Allianz SE executive leadership program at IMD Business School in Shanghai, China in November 2003.

## **B. Compensation**

For the year ended June 30, 2023, noco-noco paid an aggregate of approximately S\$0.2 million in cash compensation and benefits in kind to noco-noco's executive officers as a group. In Singapore, noco-noco is required by the applicable laws and regulations to make contributions, as employers, to the Central Provident Fund for executive officers who are employed by noco-noco as prescribed under the Central Provident Fund Act. The contribution rates vary, depending on the age of the executive officers, and whether such executive officer is a Singapore citizen or permanent resident (contributions are not required or permitted in respect of a foreigner on a work pass). Save as aforesaid, noco-noco's executive officers do not receive pension, retirement or other similar benefits, and noco-noco has not set aside or accrued any amount to provide cash benefits to its executive officers. noco-noco paid an

aggregate of S\$45,000 in cash compensation to its independent directors for the year ended June 30, 2023. noco-noco is not a party to any agreements with its executive officers and directors that provide for benefits upon termination of employment.

## [Table of Contents](#)

### Share Incentive Plan

#### *2023 Share Incentive Plan*

In February 2023, our board of directors adopted, and in August 2023, our shareholders approved, the noco-noco Inc. 2023 Equity Incentive Plan (the “**PubCo Incentive Plan**”). As of the date of this Report, under the PubCo 2023 Plan, dividend equivalents, options, restricted shares, restricted share units, share appreciation rights or other rights or benefits to purchase 6,621,822 PubCo Ordinary Shares were outstanding.

The following summarizes the material terms of the PubCo Incentive Plan:

*Shares Subject to the PubCo Incentive Plan.* Under the terms of the Shareholders’ Agreement, the maximum number of PubCo Ordinary Shares that may be issued under the PubCo Incentive Plan from time to time is five percent (5%) of the fully diluted share capital of PubCo as of the date of determination. The maximum aggregate number of PubCo Ordinary Shares which may be subject to awards under the PubCo Incentive Plan initially shall be an aggregate number equal to 6,961,159 (assuming no redemptions of PNAC public shares). The aggregate number of PubCo Ordinary Shares reserved for awards under the PubCo Incentive Plan will automatically increase on July 1 of each year, for a period of not more than ten (10) years, commencing on July 1 of the year following the year in which the effective date occurs and ending on (and including) July 1, 2033, in an amount equal to five percent (5%) of the total number of PubCo Ordinary Shares outstanding on June 30 of the preceding calendar year. Notwithstanding the foregoing, our board may act prior to July 1 of a given year to provide that there will be no July 1 increase for such year or that the increase for such year will be a lesser number of PubCo Ordinary Shares than provided in the PubCo Incentive Plan.

*Plan Administration.* Our board of directors itself or any committee delegated by our board of directors will administer the PubCo Incentive Plan. The administrator, among other things, determines the participants to receive awards, when and how awards will be granted, the type of award to be granted, the number of awards to be granted, and the other terms and conditions of each award.

*Capitalization Adjustment.* In the event that the number of outstanding PubCo Ordinary Shares is changed by a share dividend, recapitalization, share split, reverse share split, subdivision, combination, reclassification or other change in our capital structure affecting PubCo Ordinary Shares without consideration, then in order to prevent diminution or enlargement of the benefits or potential benefits intended to be made available under the PubCo Incentive Plan: (a) the number of PubCo Ordinary Shares reserved for issuance under this Plan, (b) the applicable price per PubCo Ordinary Share and number of PubCo Ordinary Shares subject to outstanding awards will be proportionately adjusted, subject to any required action by the our board of directors or our shareholders and compliance with applicable law; provided, however, that fractions of a PubCo Ordinary Share will not be issued but will either be paid in cash at the fair market value of such fraction of a PubCo Ordinary Share or will be rounded down to the nearest whole PubCo Ordinary Share, as determined by the administrator.

*Types of Awards.* The PubCo Incentive Plan permits the grants of dividend equivalents, options, restricted shares, restricted share units, and share appreciation rights.

*Eligibility.* Our employees, directors and consultants or any of our subsidiaries and affiliates are eligible to participate in the PubCo Incentive Plan, except that pursuant to any applicable laws, grants to non-employees are prohibited.

*Award Agreements.* Awards granted under the PubCo Incentive Plan are evidenced by award agreements confirming the grant of awards.

*Conditions of Awards.* The administrator determines the provisions, terms and conditions of each dividend equivalent, option, restricted share, restricted share unit, and share appreciation right granted under the PubCo 2023 Plan, including but not limited to the term, timing of grant, and the vesting schedule of the awards.

*Transferability.* The awards and all rights thereunder are exercisable only by the participants and are not assignable or transferable, unless otherwise permitted in the award agreement.

*Termination of Employment.* Except as may otherwise be provided by the administrator in an award agreement, a grantee’s rights in all dividend equivalent rights shall automatically terminate upon the grantee’s termination of employment (or cessation of service relationship) with us and our subsidiaries for any reason.

*Term; Amendment.* Unless suspended or terminated earlier, the PubCo Incentive Plan has a term of ten years from the date it was adopted by our board of directors (or, if earlier, the date it was approved by our shareholders). Our board of directors has the authority to, at any time; (i) terminate or amend the PubCo Incentive Plan in any respect, including without limitation amendment of any form of award agreement or other instrument to be executed pursuant to PubCo Incentive Plan, provided that any amendment or termination that has a material and adverse effect on the rights of grantees shall require their consents; and, (ii) terminate any and all outstanding



options or share appreciation rights upon a winding up or liquidation of our company, followed by the payment of creditors and the distribution of any remaining funds to the our shareholders.

## [Table of Contents](#)

### C. Board Practices

#### Board of Directors

Our board of directors currently consists of six directors, three of which are independent. As a controlled company and foreign private issuer, we have elected to not have a majority of our board consist of independent directors. The Amended and Restated Memorandum and Articles of Association provides that the minimum number of directors shall be three, which may be increased or reduced by ordinary resolution, and the maximum number of directors shall be unlimited unless fixed by ordinary resolution. Except as provided in the Amended and Restated Memorandum and Articles of Association, a director may vote in respect of any contract or transaction in which he/she is interested provided that the nature and extent of the interest of any director in any such contract or transaction is disclosed at or prior to its consideration and any vote thereon, and such director may be counted in the quorum at any meeting of directors at which any such contract or transaction is considered. A director who is interested in a contract or proposed contract with us must declare the nature of his interest at a meeting of the directors or otherwise be made in writing. None of our non-employee director has a service contract with us that provides for benefits upon termination of service.

#### Board Diversity Matrix

The table below provides certain information regarding the diversity of our board of directors as of the date of this Report, pursuant to Nasdaq's Board Diversity Rule.

##### Board Diversity Matrix

Country of Principal Executive Office	Singapore
Foreign Private Issuer	Yes
Disclosure Prohibited under Home Country Law	No
Total Number of Directors	6

	Female	Male	Non-Binary	Did Not Disclose Gender
<b>Part I: Gender Identity</b>				
Directors	1	5		
<b>Part II: Demographic Background</b>				
Underrepresented Individual in Home Country Jurisdiction		0		
LGBTQ+		0		
Did Not Disclose Demographic Background		0		

#### Duties of Directors

Under the laws of the Cayman Islands, our directors owe certain fiduciary duties to us, including a duty of loyalty, a duty to act honestly, and a duty to act in good faith in what they consider to be in our best interests. Our directors must also exercise their powers only for a proper purpose. Our directors also have a duty to exercise the skills they actually possess and such care and diligence that a reasonably prudent person would exercise in comparable circumstances.

In fulfilling their duty of care to us, our directors must ensure compliance with our memorandum and articles of association as may be amended from time to time. Our company has a right to seek damages against any director who breaches a duty owed to us.

The functions and powers of our board of directors include, among others:

- convening shareholders' annual general meetings and reporting its work to shareholders at such meetings;
- declaring dividends and distributions;
- appointing officers and determining the term of office of officers; and
- exercising the borrowing powers of our company and mortgaging the property of our company.

#### Appointment and Removal of Directors

The Amended and Restated Memorandum and Articles of Association does not limit the maximum number of directors, though this number may be fixed by ordinary resolution.

The Amended and Restated Memorandum and Articles of Association provides that first directors shall be appointed in writing by the subscriber or subscribers to the Amended and Restated Memorandum and Articles of Association, or a majority of them, and thereafter, the directors may be appointed and removed by our shareholders by ordinary resolution or by the directors.

## [Table of Contents](#)

The Amended and Restated Memorandum and Articles of Association provides for certain circumstances whereby a director's office shall be terminated forthwith. Our directors have a fixed term expiring at the next-following general meeting of PubCo unless re-appointed or removed pursuant to the Amended and Restated Memorandum and Articles of Association, and there is no requirement for them to retire by rotation nor to make themselves eligible for re-election. Each director shall remain in office until the end of his/her term or if he or she is removed by ordinary resolution and the office of a director shall be vacated automatically if the director, among other things, (i) he or she is prohibited by the law of the Cayman Islands from acting as a director; (ii) he or she is made bankrupt or makes an arrangement or composition with his/her creditors generally; (iii) he or she resigns his/her office by notice to us; (iv) he or she only held office as a director of our Company for a fixed term and such term expires; (v) in the opinion of a registered medical practitioner by whom he/she is being treated he/she becomes physically or mentally incapable of acting as a director; (vi) he/she is made subject to any law relating to mental health or incompetence, whether by court order or otherwise; (vii) without the consent of the other directors, he/she is absent from meetings of directors for a continuous period of six months; or (viii) is removed from office pursuant to any other provision of the Amended and Restated Memorandum and Articles of Association.

### **Committees of the Board of Directors**

Our board of directors have established an audit committee, a compensation committee, and a nominating and corporate committee. Each committee's members and functions are described below.

#### ***Audit Committee***

The audit committee consists of Mr. Timothy Lai Wah Teo, Mr. Heizo Takenaka and Mr. Jean- Francois Raymond Roger Minier. Mr. Timothy Lai Wah Teo is the chairperson of the audit committee and he satisfies the criteria of an audit committee financial expert as set forth under the applicable rules of the SEC. Each of Mr. Timothy Lai Wah Teo, Mr. Heizo Takenaka and Mr. Jean-Francois Raymond Roger Minier satisfies the requirements for an "independent director" within the meaning of the Nasdaq listing rules and the criteria for independence set forth in Rule 10A-3 of the Exchange Act.

The audit committee oversees our accounting and financial reporting processes. The audit committee is responsible for, among other things:

- overseeing the relationship with our independent auditors, including:
  - appointing, retaining and determining the compensation of our independent auditors;
  - approving auditing and pre-approving non-auditing services permitted to be performed by the independent auditors;
  - discussing with the independent auditors the overall scope and plans for their audits and other financial reviews;
  - reviewing a least annually the qualifications, performance and independence of the independent auditors;
  - reviewing reports from the independent auditors regarding all critical accounting policies and practices to be used by us and all other material written communications between the independent auditors and management; and
  - reviewing and resolving any disagreements between management and the independent auditors regarding financial controls or financial reporting;
- overseeing the internal audit function, including conducting an annual appraisal of the internal audit function, reviewing and discussing with management the appointment of the head of internal audit, at least quarterly meetings between the chairperson of the audit committee and the head of internal audit, reviewing any significant issues raised in reports to management by internal audit and ensuring that there are no unjustified restrictions or limitations on the internal audit function and that it has sufficient resources;
- reviewing and recommending all related party transactions to our board of directors for approval, and reviewing and approving all changes to our related party transactions policy;
- reviewing and discussing with management the annual audited financial statements and the design, implementation, adequacy and effectiveness of our internal controls;
- overseeing risks and exposure associated with financial matters; and
- establishing and overseeing procedures for the receipt, retention and treatment of complaints received from our employees regarding accounting, internal accounting controls or audit matters and the confidential, anonymous submission by our employees of concerns regarding questionable accounting, auditing and internal control matters.

#### ***Compensation Committee***

The compensation committee consists of Mr. Heizo Takenaka, Mr. Jean-Francois Raymond Roger Minier and Mr. Masataka Matsumura. Mr. Heizo Takenaka is the chairperson of the compensation committee. Each of Mr. Heizo Takenaka and Mr. Jean-Francois Raymond Roger Minier satisfies the requirements for an “independent director” within the meaning of the Nasdaq listing

## [Table of Contents](#)

rules. As a controlled company and foreign private issuer, we have elected to not have our compensation committee consist of entirely independent directors.

The compensation committee is responsible for, among other things:

- reviewing at least annually the goals and objectives of our executive compensation plans, and amending, or recommending that our board of directors amend, these goals and objectives if the committee deems it appropriate;
- reviewing at least annually our executive compensation plans in light of our goals and objectives with respect to such plans, and, if the committee deems it appropriate, adopting, or recommending to our board of directors the adoption of, new, or the amendment of existing, executive compensation plans;
- evaluating at least annually the performance of our executive officers in light of the goals and objectives of our compensation plans, and determining and approving the compensation of such executive officers, provided that Mr. Masataka Matsumura shall not participate in such determination and approval relating to him personally;
- evaluating annually the appropriate level of compensation for our board of directors and committee service by non-employee directors;
- reviewing and approving any severance or termination arrangements to be made with any of our executive officers, provided that Mr. Masataka Matsumura shall not participate in such determination and approval relating to him personally; and
- reviewing perquisites or other personal benefits to our executive officers and directors and recommend any changes to our board of directors; and administering our equity plans.

### ***Nominating and Corporate Governance Committee***

Our nominating and corporate governance committee consists of Mr. Heizo Takenaka, Mr. Timothy Lai Wah Teo and Mr. Masataka Matsumura. Each of Mr. Heizo Takenaka and Mr. Timothy Lai Wah Teo satisfies the requirements for an “independent director” within the meaning of the Nasdaq listing rules. Mr. Heizo Takenaka is chairperson of the nominating and corporate governance committee. As a controlled company and foreign private issuer, we have elected to not have our nominating and corporate governance committee consist of entirely independent directors.

The nominating and corporate governance committee assists our board of directors in evaluating nominees to our board of directors and its committees. In addition, the nominating and corporate governance committee will be responsible for, among other things:

- reviewing annually with our board of directors the characteristics such as knowledge, skills, qualifications, experience and diversity of directors;
- overseeing director training and development programs; and
- advising our board of directors periodically with regards to significant developments in the law and practice of corporate governance as well as compliance with applicable laws and regulations, and making recommendations to our board of directors on all matters of corporate governance and on any remedial action to be taken.

### **Code of Business Conduct and Ethics**

We have adopted a Code of Business Conduct and Ethics applicable to our directors, officers and employees. We seek to conduct business ethically, honestly, and in compliance with applicable laws and regulations. Our Code of Business Conduct and Ethics sets out the principles designed to guide our business practices with integrity, respect and dedication. The code applies to all directors, officers, employees and extended workforce, including our directors and executive officers. We expect our suppliers, contractors, consultants, and other business partners to follow the principles set forth in its code when providing goods and services to us or acting on our behalf.

### **Employment Agreements and Indemnification Agreements**

We have entered into an employment agreement with each of our executive officers. The employment of the executive officers under these employment agreements is for an indefinite period, but may be terminated by us for cause at any time without advance notice or for any other reason by giving prior written notice or by paying certain compensation, and the executive officer may terminate his or her employment at any time by giving us prior written notice. The employment agreements with the executive officers also include confidentiality and non-disclosure restrictions and non-competition and non-solicitation restrictions that apply during employment and for certain periods following termination of employment.



## [Table of Contents](#)

We have entered into indemnification agreements with each of our directors. Under these agreements, we may agree to indemnify our director against certain liabilities and expenses incurred by such persons in connection with claims made by reason of their being a director of us.

### D. Employees

As of June 30, 2023, we had 12 employees based primarily in Singapore, all of which were full-time employees. A majority of our employees are engaged in business development, operations, finance, and administration. None of our employees is either represented by a labor union or subject to a collective bargaining agreement. We enter into non-competition, non-solicitation and confidentiality agreements or service agreement or employment agreement that contains non-competition, non-solicitation and confidentiality clauses with our employees.

### E. Share Ownership

Please see “Item. 7 Major Shareholders and Related Party Transactions” below.

## ITEM 7. MAJOR SHAREHOLDERS AND RELATED PARTY TRANSACTIONS

### A. Major Shareholders

The following table sets forth information regarding the beneficial ownership of Ordinary Shares as of the date hereof by:

- each person known by us to be the beneficial owner of more than 5% of Ordinary Shares;
- each of our directors and executive officers; and
- all our directors and executive officers as a group.

Beneficial ownership is determined according to the rules of the SEC, which generally provide that a person has beneficial ownership of a security if that person possesses sole or shared voting or investment power over that security. A person is also deemed to be a beneficial owner of securities that person has a right to acquire within 60 days including, without limitation, through the exercise of any option, warrant or other right or the conversion of any other security. Such securities, however, are deemed to be outstanding only for the purpose of computing the percentage beneficial ownership of that person but are not deemed to be outstanding for the purpose of computing the percentage beneficial ownership of any other person. Under these rules, more than one person may be deemed to be a beneficial owner of the same securities.

As of the date of this Report, there are 135,430,452 Ordinary Shares issued and outstanding.

Unless otherwise indicated, we believe that all persons named in the table below have sole voting and investment power with respect to all shares of voting shares beneficially owned by them.

Name of Beneficial Owner	Ordinary Shares Beneficially Owned Immediately After Closing of the Business Combination	
	Ordinary Shares	% of Total Ordinary Shares
<b><i>Directors and Executive Officers</i></b> <sup>(1)</sup>		
Masataka Matsumura <sup>(2)</sup>	55,427,248	40.9
Mari Matsushita	—	—
Yuta Akakuma	—	—
Ng Wee Kiat (Darren)	—	—
Tatsuo Mori	—	—
Timothy Lai Wah Teo	—	—
Heizo Takenaka	—	—
Jean-Francois Raymond Roger Minier	—	—
All executive officers and directors as a group (eight individuals)	55,427,248	40.9
<b><i>5.0% Shareholders</i></b>		
3DOM Alliance <sup>(3)</sup>	90,918,596	67.1
Future Science Research <sup>(4)</sup>	9,331,520	6.9



- (1) The business address for the directors and executive officers of the Company will be 4 Shenton Way, #04-06 SGX Centre II, Singapore 068807.

## [Table of Contents](#)

- (2) Represents shares beneficially owned by Mr. Masataka Matsumura through 3DOM Alliance and Future Science Research.
- (3) Consists of 90,918,596 Ordinary Shares directly held by 3DOM Alliance, a company incorporated under the laws of Japan, which is the majority shareholder of the Company. Mr. Masataka Matsumura is the largest shareholder of 3DOM Alliance, who holds 50.7% its equity interests, as well as the Chief Executive Officer and a Director of the Company.
- (4) Consists of 9,331,520 Ordinary Shares directly held by Future Science Research, a company incorporated under the laws of Japan, which is wholly owned by Mr. Masataka Matsumura.

We have experienced significant changes in the percentage ownership held by major shareholders as a result of the Business Combination. Prior to the consummation of the Business Combination, the sole shareholder of our Company is Dongfeng Wang, the Chief Executive Officer and Chairman of PNAC.

## **B. Related Party Transactions**

### **Promissory Note**

On August 1, 2020, noco-noco issued a promissory note to 3DOM Alliance (the “Note”). The Note provides for borrowings upon the request of noco-noco, on one or more occasions, up to the principal amount of S\$1.0 million (\$0.7 million). The principal amount was extended to S\$3.0 million (\$2.2 million) on January 23, 2023, and further extended to S\$8.0 million (\$5.8 million) on February 6, 2023. No interest shall accrue to any loans under the Note. There are no payment schedules under the Note; however, the Note must be repaid upon 3DOM Alliance’s request or certain events of default. As of June 30, 2023, we had drawn down an aggregate amount of S\$4.8 million (\$3.6 million).

### **Issuance of Shares pursuant to Debt-to-Equity Swaps**

On October 22, 2021, noco-noco allotted and issued 15,478 new ordinary shares in its capital, at \$100 per share, to 3DOM Alliance, pursuant to a debt-to-equity swap which both parties agreed to convert noco-noco’s debt of \$1.5 million owed to 3DOM Alliance into new ordinary shares in the capital of noco-noco.

On July 15, 2022, noco-noco allotted and issued another 759 new ordinary shares in its capital, at the issue price of \$1,041.22, to 3DOM Alliance, pursuant to another debt-to-equity swap which both parties agreed to convert noco-noco’s debt of \$0.8 million owed to 3DOM Alliance into new ordinary shares in the capital of noco-noco.

### **2021 License-in Agreement**

On August 18, 2021, noco-noco entered into an exclusive, irrevocable license-in agreement (the “**2021 license-in agreement**”) with 3DOM Alliance. Pursuant to the agreement, 3DOM Alliance granted a license to certain of its proprietary patents, trademarks and other intellectual properties to noco-noco, in return for royalties of the sum equal to 1.5% of noco-noco’s revenue. The 2021 license-in agreement was amended once on August 29, 2022 and was terminated on November 22, 2022.

### **License-in Agreement**

On November 22, 2022, noco-noco entered into a new exclusive, irrevocable license-in agreement with 3DOM Alliance. Pursuant to such agreement, 3DOM Alliance granted noco-noco the exclusive rights to utilize certain of its proprietary and licensed-in patents and other intellectual property, as well as confidential yet critical know-how and other information for a perpetual term, in return for quarterly royalties equal to three percent (3%) of the gross profit generated using each of 3DOM IP Rights. In addition, noco-noco is obligated to pay a one-off, refundable upfront payment of \$30 million licensing fee to 3DOM Alliance. Such upfront payment shall be credited against any royalties under the agreement such that the amount of the upfront payment shall be deducted from the royalties when due and payable. In the event that the upfront payment has any remaining amount after the last deduction from the royalties at the end of a five-year period from the last instalment of the upfront payment, the remaining unutilized amount shall be refunded to us at our request. Pursuant to a supplemental agreement to the license-in agreement dated May 10, 2023 (the “**Supplemental Agreement**”), the upfront payment shall be payable over a series of instalments after the consummation of the Business Combination, in such amounts and manner, and pursuant to such repayment schedule as may be agreed between 3DOM Alliance and us. Both parties shall negotiate the instalment plan in good faith, taking into consideration our working capital needs as well as our liquidity and available capital resources after the consummation of the Business Combination. As of the date of this Report, we had not paid any upfront payments to 3DOM Alliance yet. See “*Business — Relationship with 3DOM Alliance*” for more details.

### **Employment Agreements and Indemnification Agreements**

See the section headed “*Item 6. Directors, Senior Management and Employees — C. Board Practices — Employment Agreements and Indemnification Agreements.*”



## [Table of Contents](#)

### **Lock-up Agreements**

Prior to the consummation of the Business Combination, PNAC, PubCo, PNAC Initial Insiders (as defined in the Lock-up Agreement), and certain of the shareholders of noco-noco entered into a lock-up agreement (the “**Lock-up Agreement**”), pursuant to which the Initial Insiders and certain shareholders of noco-noco agreed not to sell, assign, offer to sell, contract or agreement to sell, hypothecate, pledge, grant of any option to purchase or otherwise dispose of or agreement to dispose of, directly or indirectly, or establishment or increase of a put equivalent position or liquidation with respect to or decrease of a call equivalent position within the meaning of Section 16 of the Securities Exchange Act of 1934, as amended, and the rules and regulations of the Commission promulgated thereunder with respect to, any of the Lock-up Shares (as defined in the Lock-up Agreement); (b) entry into any swap or other arrangement that transfers to another, in whole or in part, any of the economic consequences of ownership of any of the Lock-up Shares, whether any such transaction is to be settled by delivery of such Lock-up Shares, in cash or otherwise; (c) make public announcement of any intention to effect any transaction specified in clause (a) or (b) above; or (d) engage in any short sales (as defined in the Lock-up Agreement) with respect to any security of PubCo, for a period of six months following the Share Exchange Closing Date with respect to PNAC Founder Shares and PubCo Ordinary Shares that certain shareholders of noco-noco will receive in connection with the Share Exchange, and for a period of 30 days following the Share Exchange Closing Date with respect to PNAC Private Shares and Working Capital Loan Shares, if any. Such lock-up period may end earlier if certain conditions occur as provided in the Lock-up Agreement. The lock-up restrictions imposed on 3DOM and Future Science Research Inc. (“FSR”, together with 3DOM, the “**Holders**”) were waived by us on and effective from September 29, 2023, as the Holders desire to pledge all or a portion of their Lock-up Shares for the purpose of obtaining financing by third party lender(s) (the “**Financing**”), the proceeds of which will be used in accordance with the requirements set out in the definitive documents for the Financing.

### **Registration Rights Agreement**

PubCo and certain holders of PubCo Ordinary Shares entered into a Registration Rights Agreement, effective upon the Closing pursuant to which, among other things, PubCo agreed to undertake certain resale registration obligations in accordance with the Securities Act and the holders have been granted certain demand and piggyback registration rights.

As provided in the Registration Rights Agreement, PubCo must upon the demand of the registration rights holders, use reasonable efforts to cause to be declared effective as soon as practicable thereafter, a registration statement for a registration on Form F-1 (“**Form F-1**”) covering the resale of all registrable securities held by the holders of registration rights on a delayed or continuous basis. Following the filing of the Form F-1, PubCo has agreed to use reasonable efforts to convert the Form F-1 to a shelf registration on Form F-3, and/or to file and cause to become effective a shelf registration on Form F-3, as soon as practicable and in any event after PubCo is eligible to use Form F-3. A majority-in-interest of the Demanding Holders (as defined in the Registration Rights Agreement), may, subject to certain limitations described in the Registration Rights Agreement, make demand for an underwritten offering of all or any portion of their registrable securities pursuant to the registration statement, up to certain number of times depending on the type of registrable securities that such holder holds; provided that PubCo will not be required to effectuate (i) with respect to any Tranche A Registrable Securities (as defined in the Registration Rights Agreement), more than an aggregate of one (1) registration pursuant to a demand registration, (ii) with respect to any Tranche B Registrable Securities (as defined in the Registration Rights Agreement), more than an aggregate of one (1) registration pursuant to a demand registration, (iii) with respect to any Tranche C Registrable Securities (as defined in the Registration Rights Agreement), more than an aggregate of one (1) registration pursuant to a demand registration, and (iv) with respect to any Tranche D Registrable Securities (as defined in the Registration Rights Agreement), more than an aggregate of one (1) registration pursuant to a demand registration; provided, however, that a registration shall not be counted for such purposes unless a Form F-1 or any similar long-form registration statement that may be available at such time has become effective and all of the registrable securities requested by the requesting holders to be registered on behalf of the requesting holders in such Form F-1 registration have been sold, in accordance with the Registration Rights Agreement. In addition, holders of registrable securities have certain “piggy-back” registration rights with respect to registration statements filed after the expiration of any lock-up to which such securities are subject pursuant to any Lock-Up Agreement, with certain customary exceptions. PubCo will bear all costs and expenses incurred in connection with the filing of any such registration statements.

### **Payoff Letter**

On October 10, 2023, the Company entered into a payoff letter agreement (the “**Payoff Letter**”) with PNAC, PNCPS and WestPark Capital, Inc. (“**WestPark**”), in connection with: (i) the engagement letter entered into by and among PNAC, PNCPS and WestPark as of October 25, 2022 (the “**Financial Advisory Engagement**”), (ii) the engagement letter entered into by and between PNAC and PNCPS as of October 25, 2022 (as amended by an amendment dated January 31, 2023 setting forth the compensation therefor, the “**Business Combination Advisory Engagement**”) and (iii) the placement agent agreement entered into by and between PNAC and PNCPS as of April 30, 2023 (the “**Placement Agent Agreement**,” together with Financial Advisory Engagement and Business Combination Advisory Engagement, the “**Prime Agreements**”). Pursuant to the Payoff Letter, the Company would undertake certain amounts and obligations to PNCPS and WestPark (the “**Payoff Amount**”) under the Prime Agreements in connection with and as a result of the Business Combination. Each of PNCPS and WestPark agreed to equitize the entire Payoff Amount by subscribing for

(including having its designated person subscribe for) such number of the Company's ordinary shares (the "Payoff Shares"), among others under the Payoff Letter. Upon the execution and delivery of the Payoff Letter, the Prime Agreements were terminated automatically without further force and effect and any claims thereunder should be released.

## [Table of Contents](#)

### **Equity Incentive Plans**

See “*Item 6. Directors, Senior Management and Employees — B. Compensation — Share Incentive Plan.*”

### **C. Interests of Experts and Counsel**

None.

## **ITEM 8. FINANCIAL INFORMATION**

### **A. Consolidated Statements and Other Financial Information**

#### **Financial Statements**

Consolidated financial statements have been filed as part of this Report. See Item 18 “Financial Statements.”

#### **Legal Proceedings**

From time to time, we may become involved in additional legal proceedings arising in the ordinary course of its business. We are currently involved in a civil litigation (the "Litigation") in Singapore relating to an alleged breach of a share swap agreement, pursuant to which, subject to certain condition precedents by the claimant, we would engage in a share swap (the “Share Swap”) with the claimant where we will hold 24% of the claimant’s total equity interests and the claimant would hold 8% (the “Minority Interests”) of our total equity interests. In the Litigation, the claimant alleges that we have substantially breached the contract by not performing the Share Swap, and demands, inter alia, that the court orders specific performance of the Share Swap. On October 31, 2023, with respect to the Litigation, we entered into a settlement agreement with the claimant under which, among others, that (i) the claimant and us have irrevocably and unconditionally agreed to a full and final settlement of any Claims (as defined therein), (ii) the claimant and us have further agreed to unconditionally and absolutely discharge and release each other, its affiliates and other Released Persons (as defined therein) with immediate effect from any and all Claims, and (iii) all parties involved in the litigation shall discontinue its respective legal proceeding under the Litigation with no order as to costs and shall file the Notice of Discontinuance within a stipulated period of time, and bear its own costs in relation to the Litigation, the mediation and the settlement. The Share Swap is therefore voided and our shareholding structure will not be affected under such settlement

#### **Dividend Policy**

We may declare dividends on our Ordinary Shares from time to time. The declaration, payment and amount of any future dividends will be made at the discretion of our board of directors and will depend upon, among other things, the results of operations, cash flows and financial condition, operating and capital requirements, and other factors as our board of directors considers relevant. There is no assurance that future dividends will be paid, and if dividends are paid, there is no assurance with respect to the amount of any such dividend.

Our board of directors has complete discretion in deciding whether to distribute dividends, subject to certain restrictions under Cayman Islands law, namely that our Company may only pay dividends out of profits or share premium, and provided always that in no circumstances may a dividend be paid if this would result in the Company being unable to pay its debts as they fall due in the ordinary course of business. In addition, our shareholders may by ordinary resolution declare a dividend, but no dividend may exceed the amount recommended by our board of directors. Even if our board of directors decides to pay dividends, the timing, amount and form of future dividends, if any, will depend on, among other things, our future results of operations and cash flow, our capital requirements and surplus, the amount of distributions, if any, received by us from our subsidiaries, our financial condition, contractual restrictions and other factors deemed relevant by our board of directors.

### **B. Significant Changes**

Except as disclosed elsewhere in this Report, we have not experienced any significant changes since June 30, 2023.

## **ITEM 9. THE OFFER AND LISTING**

### **A. Offer and Listing Details**

Our Ordinary Shares and Warrants are listed on Nasdaq under the symbols “NCNC” and “NCNCW,” respectively. Holders of Ordinary Shares and Warrants should obtain current market quotations for their securities. There can be no assurance that our Ordinary Shares and/or Warrants will remain listed on Nasdaq. If we fail to comply with the Nasdaq listing requirements, our Ordinary Shares and/or Warrants could be delisted from Nasdaq. A delisting of our Ordinary Shares will likely restrict the liquidity of our Ordinary Shares and could inhibit or restrict our ability to raise additional financing, among other things.



## [Table of Contents](#)

### **B. Plan of Distribution**

Not applicable.

### **C. Markets**

Our Ordinary Shares and Warrants are listed on Nasdaq under the symbols “NCNC” and “NCNCW,” respectively.

### **D. Selling Shareholders**

Not applicable.

### **E. Dilution**

Not applicable.

### **F. Expenses of the Issue**

Not applicable.

## **ITEM 10. ADDITIONAL INFORMATION**

### **A. Share Capital**

As of the date of this Report, there were 135,430,452 Ordinary Shares that were outstanding and issued.

### **B. Memorandum and Articles of Association**

The memorandum and articles of association of the Company effective as of August 25, 2023, i.e. the Amended and Restated Memorandum and Articles of Association, are filed as part of this Report.

A summary of material terms of the articles of association of the Company is set forth in Exhibit 2.3 to this Report entitled “Description of Securities Registered under Section 12 of the Securities Exchange Act of 1934”.

### **C. Material Contracts**

Other than in the ordinary course of business and other than those described in “Explanatory Note,” “Item 4. Information on the Company,” “Item 7. Major Shareholders and Related Party Transactions—B. Related Party Transactions” or elsewhere in this annual report, including the below, we have not entered into any material contract during the two years immediately preceding the date of this annual report:

On August 13, 2023, we entered into a Forward Purchase Agreement (the “Forward Purchase Agreement”) with (i) Meteora Capital Partners, LP (“MCP”), (ii) Meteora Select Trading Opportunities Master, LP (“MSTO”), and (iii) Meteora Strategic Capital, LLC (“MSC” and, collectively with MCP and MSTO, the “Seller”) for an OTC Equity Prepaid Forward Transaction. On October 26, 2023, we further entered into a Forward Purchase Agreement Confirmation Amendment with the Seller to amend certain terms of the Forward Purchase Agreement.

On August 14, 2023, we entered into a purchase agreement (the “Purchase Agreement”) with ARENA BUSINESS SOLUTIONS GLOBAL SPC II, LTD on behalf of and for the account of SEGREGATED PORTFOLIO #9 – SPC #9 (“Arena”), which provides that, upon the terms and subject to the conditions and limitations set forth therein, we have the right to direct Arena to purchase up to an aggregate of \$150,000,000 of PubCo Ordinary Shares over the 36-month term of the Purchase Agreement. On September 18, 2023, we entered into Amendment No.1 to the Purchase Agreement to amend certain terms of the Purchase Agreement. A summary of material terms and full text of such agreements is set forth in the Registration Statement on Form F-1 filed with the SEC on September 19, 2023, which is incorporated herein by reference.

### **D. Exchange Controls**

There are no governmental laws, decrees, regulations or other legislation in the Cayman Islands that may affect the import or export of capital, including the availability of cash and cash equivalents for use by the Company, or that may affect the remittance of dividends, interest, or other payments by the Company to non-resident holders of its ordinary shares, assuming the absence of applicable United Nations sanctions as implemented or otherwise adopted under the laws of the Cayman Islands. There is no



limitation imposed by laws of Cayman Islands or in the Company's articles of association on the right of non-residents to hold or vote shares.”

## [Table of Contents](#)

### **E. Taxation**

#### **Material United States Federal Income Tax Considerations**

The following is a discussion of certain material U.S. federal income tax considerations generally applicable to the acquisition, ownership, and disposition of Ordinary Shares by a “U.S. Holder.” This discussion applies only to Ordinary Shares that are held by a U.S. Holder as “capital assets” within the meaning of Section 1221 of the Code (generally, property held for investment). This discussion does not describe all U.S. federal income tax considerations that may be relevant to a U.S. Holder in light of such U.S. Holder’s particular circumstances, nor does it address any state, local, or non-U.S. tax considerations, any non-income tax (such as gift or estate tax) considerations, the alternative minimum tax, the special tax accounting rules under Section 451(b) of the Code, the Medicare contribution tax on net investment income, or any tax consequences that may be relevant to U.S. Holders that are subject to special tax rules, including, without limitation:

- banks or other financial institutions;
- insurance companies;
- mutual funds;
- pension or retirement plans;
- S corporations;
- broker or dealers in securities or currencies;
- traders in securities that elect mark-to-market treatment;
- regulated investment companies;
- real estate investment trusts;
- trusts or estates;
- tax-exempt organizations (including private foundations);
- persons that hold Ordinary Shares as part of a “straddle,” “hedge,” “conversion,” “synthetic security,” “constructive sale,” or other integrated transaction for U.S. federal income tax purposes;
- persons that have a functional currency other than the U.S. dollar;
- certain U.S. expatriates or former long-term residents of the United States;
- persons owning (directly, indirectly, or constructively) 5% (by vote or value) or more of our shares;
- persons that acquired Ordinary Shares pursuant to an exercise of employee stock options or otherwise as compensation;
- partnerships or other entities or arrangements treated as pass-through entities for U.S. federal income tax purposes and investors in such entities;
- “controlled foreign corporations” within the meaning of Section 957(a) of the Code;
- “passive foreign investment companies” within the meaning of Section 1297(a) of the Code; and
- corporations that accumulate earnings to avoid U.S. federal income tax.

If a partnership (including an entity or arrangement treated as a partnership for U.S. federal income tax purposes) holds Ordinary Shares, the tax treatment of a partner in such partnership generally will depend on the status of the partner and the activities of the partnership and the partner. Partnerships holding Ordinary Shares should consult their tax advisors regarding the tax consequences in their particular circumstances.

This discussion is based on the Code, the U.S. Treasury regulations promulgated thereunder, administrative rulings, and judicial decisions, all as currently in effect and all of which are subject to change or differing interpretation, possibly with retroactive effect. Any such change or differing interpretation could alter the tax consequences described herein. Furthermore, there can be no assurance that the Internal Revenue Service (the “IRS”) will not challenge the tax considerations described herein and that a court will not sustain such challenge.

For purposes of this discussion, a “U.S. Holder” is a beneficial owner of Ordinary Shares, that is, for U.S. federal income tax purposes:

- an individual who is a U.S. citizen or resident of the United States;
- a corporation (including an entity treated as a corporation for U.S. federal income tax purposes) created or organized in or

under the laws of the United States, any state thereof, or the District of Columbia;

## [Table of Contents](#)

- an estate the income of which is subject to U.S. federal income taxation regardless of its source; or
- a trust (i) if a court within the United States is able to exercise primary supervision over the administration of the trust and one or more “United States persons” within the meaning of Section 7701(a)(30) of the Code have the authority to control all substantial decisions of the trust or (B) that has in effect a valid election under applicable U.S. Treasury regulations to be treated as a United States person.

THIS DISCUSSION IS FOR GENERAL INFORMATIONAL PURPOSES ONLY AND IS NOT TAX ADVICE. U.S. HOLDERS SHOULD CONSULT THEIR TAX ADVISORS REGARDING THE TAX CONSEQUENCES OF THE ACQUISITION, OWNERSHIP, AND DISPOSITION OF ORDINARY SHARES IN THEIR PARTICULAR CIRCUMSTANCES.

### ***Distributions on Ordinary Shares***

Subject to the PFIC rules discussed below under “—*Passive Foreign Investment Company Rules*,” distributions on Ordinary Shares generally will be taxable as a dividend for U.S. federal income tax purposes to the extent paid from our current or accumulated earnings and profits, as determined under U.S. federal income tax principles. Such distributions in excess of our current and accumulated earnings and profits will constitute a return of capital that will be applied against and reduce (but not below zero) the applicable U.S. Holder’s adjusted tax basis in its Ordinary Shares. Any remaining excess will be treated as capital gain realized on the sale or other taxable disposition of the Ordinary Shares and will be treated as described below under “—*Sale or Other Taxable Disposition of Ordinary Shares*.” Notwithstanding the foregoing, our Company does not intend to maintain calculations of its earnings and profits as determined for U.S. federal income tax purposes. Consequently, distributions generally will be reported as dividend income for U.S. information reporting purposes. Subject to the PFIC rules described below, dividends paid by a non-U.S. corporation generally will be taxed at the preferential tax rates applicable to long-term capital gain of non-corporate taxpayers if (a) such non-U.S. corporation is eligible for the benefits of certain U.S. treaties or the dividend is paid by such non-U.S. corporation with respect to stock that is readily tradable on an established securities market in the United States, (b) the U.S. Holder receiving such dividend is an individual, estate, or trust, and (c) such dividend is paid on shares that have been held by such U.S. Holder for at least 61 days during the 121-day period beginning 60 days before the “ex-dividend date.” If the requirements of the immediately preceding sentence are not satisfied, a dividend paid by a non-U.S. corporation to a U.S. Holder, including a U.S. Holder that is an individual, estate, or trust, generally will be taxed at ordinary income tax rates (and not at the preferential tax rates applicable to long-term capital gains). The dividend rules are complex, and each U.S. Holder should consult its own tax advisor regarding the dividend rules. Any such dividends paid in a currency other than the U.S. dollar generally will be the U.S. dollar amount calculated by reference to the exchange rate in effect on the date of actual or constructive receipt of the dividend payment, regardless of whether the payment is in fact converted into U.S. dollars at that time. A U.S. Holder may have foreign currency gain or loss if the dividend is converted into U.S. dollars after the date of actual or constructive receipt of the dividend payment.

Taxing jurisdictions other than the United States may withhold taxes from distributions on Ordinary Shares, and a U.S. Holder may be eligible for a reduced rate of withholding to the extent there is an applicable tax treaty between the applicable taxing jurisdiction and the United States and/or may be eligible for a foreign tax credit against the U.S. Holder’s U.S. federal income tax liability. Dividends received generally will be income from non-U.S. sources, which may be relevant in calculating your U.S. foreign tax credit limitation. Such non-U.S. source income generally will be “passive category income”, which is treated separately from other types of income for purposes of computing the foreign tax credit allowable to you. The rules with respect to foreign tax credits are complex and involve the application of rules that depend on a U.S. Holder’s particular circumstances. You should consult your own tax advisor to determine the foreign tax credit implications of owning the Ordinary Shares.

### ***Sale or Other Taxable Disposition of Ordinary Shares***

Subject to the PFIC rules discussed below under “—*Passive Foreign Investment Company Rules*,” upon any sale or other taxable disposition of Ordinary Shares, a U.S. Holder generally will recognize gain or loss in an amount equal to the difference, if any, between (i) the sum of (A) the amount of cash and (B) the fair market value of any other property received in such sale or disposition and (ii) the U.S. Holder’s adjusted tax basis in the Ordinary Shares. Any such gain or loss generally will be capital gain or loss and will be long-term capital gain or loss if the U.S. Holder’s holding period for such Ordinary Shares exceeds one year. Long-term capital gain recognized by non-corporate U.S. Holders generally will be taxed at currently preferential long-term capital gains rates. The deductibility of capital losses is subject to limitations. For foreign tax credit purposes, any such gain or loss generally will be treated as U.S. source gain or loss.

If the consideration received by a U.S. Holder upon a sale or other taxable disposition of Ordinary Shares is not paid in U.S. dollars, the amount realized will be the U.S. dollar value of such payment calculated by reference to the exchange rate in effect on the date of such sale or disposition. A U.S. Holder may have foreign currency gain or loss to the extent of the difference, if any, between (i) the U.S. dollar value of such payment on the date of such sale or disposition and (ii) the U.S. dollar value of such payment calculated by reference to the exchange rate in effect on the date of settlement.



## [Table of Contents](#)

U.S. Holders should consult their tax advisors regarding the tax consequences of a sale or other taxable disposition of Ordinary Shares, including the creditability of foreign taxes imposed on such sale or disposition by a taxing jurisdiction other than the United States, in their particular circumstances.

### ***Passive Foreign Investment Company Rules***

The U.S. federal income tax treatment of U.S. Holders could be materially different from that described above if we are treated as a PFIC for U.S. federal income tax purposes. In general, a non-U.S. corporation is a PFIC for U.S. federal income tax purposes for any taxable year in which (i) 50% or more of the average value of its assets (generally determined on the basis of a weighted quarterly average) consists of assets that produce, or are held for the production of, passive income, or (ii) 75% or more of its gross income consists of passive income. Passive income generally includes dividends, interest, royalties, rents, investment gains, net gains from the sales of property that does not give rise to any income and net gains from the sale of commodities (subject to certain exceptions, such as an exception for certain income derived in the active conduct of a trade or business). Cash and cash equivalents are generally treated as passive assets. The value of goodwill will generally be treated as an active or passive asset based on the nature of the income produced in the activity to which the goodwill is attributable. For purposes of the PFIC rules, a non-U.S. corporation that owns, directly or indirectly, at least 25% by value of the stock of another corporation is treated as if it held its proportionate share of the assets of the other corporation, and received directly its proportionate share of the income of the other corporation.

Based on the current and projected composition of our income and assets, and the valuation of our assets, including goodwill, we do not expect to become a PFIC in the current taxable year for U.S. federal income tax purposes. However, the Company's PFIC status for any taxable year is a factual annual determination that can be made only after the end of that year and will depend a number of factors, some of which are beyond our Company's control, such as the composition of the Company's income and assets and the value of its assets from time to time (including the value of its goodwill, which may be determined in large part by reference to the market price of the Ordinary Shares from time to time, which could be volatile). In addition, the risk of the Company being a PFIC for any taxable year will increase if its market capitalization declines substantially during that year. The above described look-through rule applicable to a corporation which we own directly or indirectly at least 25% by value of the stock may be complex to apply and certain data might not be readily available for us to make such determination. Furthermore, whether and to which extent the Company's income and assets, including goodwill, will be characterized as active or passive will depend on various factors that are subject to uncertainty, including the Company's future business plan and business activities and the application of laws that are subject to varying interpretation (including with respect to the treatment of government grants). Moreover, certain of the Company's business activities generate passive income and, although the amount of such income is currently small, the Company's risk of being a PFIC will increase if the proportion of the Company's revenue earned from such business activities increases in future taxable years. Similarly, the Company's risk of being a PFIC will increase if the proportion of the Company's revenue earned from active business activities decreases in future taxable years. Accordingly, there can be no assurances that the Company will not be a PFIC for its current or any future taxable year, and the Company's U.S. counsel expresses no opinion with respect to the Company's PFIC status for any taxable year. If our Company was currently or were to become a PFIC, U.S. Holders of Ordinary Shares would be subject to special rules and a variety of potentially adverse tax consequences under the Code.

Although PFIC status is generally determined annually, if we are determined to be a PFIC for any taxable year (or portion thereof) that is included in the holding period of a U.S. Holder in its Ordinary Shares and the U.S. Holder did not make either a mark-to-market election or a qualifying electing fund ("QEF") election or, which are referred to collectively as the "PFIC Elections" for purposes of this discussion, for the first taxable year in which we are treated as a PFIC, and in which the U.S. Holder held (or was deemed to hold) Ordinary Shares, or the U.S. Holder does not otherwise make a purging election, as described below, the U.S. Holder generally will be subject to special and adverse rules with respect to (i) any gain recognized by the U.S. Holder on the sale or other taxable disposition of its Ordinary Shares and (ii) any "excess distribution" made to the U.S. Holder (generally, any distributions to the U.S. Holder during a taxable year of the U.S. Holder that are greater than 125% of the average annual distributions received by the U.S. Holder in respect of its Ordinary Shares during the three preceding taxable years of the U.S. Holder or, if shorter, the U.S. Holder's holding period in its Ordinary Shares).

Under these rules:

- the U.S. Holder's gain or excess distribution will be allocated ratably over the U.S. Holder's holding period in its Ordinary Shares;
- the amount allocated to the U.S. Holder's taxable year in which the U.S. Holder recognized the gain or received the excess distribution, and to any period in the U.S. Holder's holding period before the first day of the first taxable year in which we are treated as a PFIC, will be taxed as ordinary income;
- the amount allocated to other taxable years (or portions thereof) of the U.S. Holder and included in the U.S. Holder's holding period will be taxed at the highest tax rate in effect for that year and applicable to the U.S. Holder; and
- an additional tax equal to the interest charge generally applicable to underpayments of tax will be imposed on the U.S.

Holder with respect to the tax attributable to each such other taxable year of the U.S. Holder.

## [Table of Contents](#)

### ***PFIC Elections***

If we are treated as a PFIC and Ordinary Shares constitute “marketable stock,” a U.S. Holder may avoid the adverse PFIC tax consequences discussed above if such U.S. Holder makes a mark-to-market election with respect to its Ordinary Shares for the first taxable year in which the U.S. Holder holds (or is deemed to hold) the Ordinary Shares and each subsequent taxable year. Such U.S. Holder generally will include for each of its taxable years as ordinary income the excess, if any, of the fair market value of its Ordinary Shares at the end of such year over its adjusted tax basis in its Ordinary Shares. The U.S. Holder also will recognize an ordinary loss in respect of the excess, if any, of its adjusted tax basis in its Ordinary Shares over the fair market value of its Ordinary Shares at the end of its taxable year (but only to the extent of the net amount of previously included income as a result of the mark-to-market election). The U.S. Holder’s adjusted tax basis in its Ordinary Shares will be adjusted to reflect any such income or loss amounts, and any further gain recognized on a sale or other taxable disposition of its Ordinary Shares will be treated as ordinary income.

The mark-to-market election is available only for “marketable stock,” generally, stock that is regularly traded on a national securities exchange that is registered with the Securities and Exchange Commission, including the Nasdaq (on which Ordinary Shares are currently listed), or on a foreign exchange or market that the IRS determines has rules sufficient to ensure that the market price represents a legitimate and sound fair market value. As such, such election generally will not apply to any of our non-U.S. subsidiaries, unless the shares in such subsidiaries are themselves “marketable stock.” As such, U.S. Holders may continue to be subject to the adverse PFIC tax consequences discussed above with respect to any lower-tier PFICs, as discussed below, notwithstanding their mark-to-market election with respect to Ordinary Shares.

If made, a mark-to-market election would be effective for the taxable year for which the election was made and for all subsequent taxable years unless Ordinary Shares cease to qualify as “marketable stock” for purposes of the PFIC rules or the IRS consents to the revocation of the election. U.S. Holders should consult their tax advisors regarding the availability and tax consequences of a mark-to-market election with respect to Ordinary Shares in their particular circumstances.

The tax consequences that would apply if we were a PFIC and a U.S. Holder made a valid QEF election would also be different from the adverse PFIC tax consequences described above. In order to comply with the requirements of a QEF election, however, a U.S. Holder generally must receive a PFIC Annual Information Statement from us. If we are determined to be a PFIC for any taxable year, we do not currently intend to provide the information necessary for U.S. Holders to make or maintain a QEF election. As such, U.S. Holders should assume that a QEF election will not be available with respect to Ordinary Shares.

If we are treated as a PFIC and a U.S. Holder failed or was unable to timely make a PFIC Election for prior periods, the U.S. Holder might seek to make a purging election to rid its Ordinary Shares of the PFIC taint. Under the purging election, the U.S. Holder will be deemed to have sold its Ordinary Shares at their fair market value and any gain recognized on such deemed sale will be treated as an excess distribution, as described above. As a result of the purging election, the U.S. Holder will have a new adjusted tax basis and holding period in the Ordinary Shares solely for purposes of the PFIC rules.

### ***Related PFIC Rules***

If we are treated as a PFIC and, at any time, has a non-U.S. subsidiary that is treated as a PFIC, a U.S. Holder generally would be deemed to own a proportionate amount of the shares of such lower-tier PFIC, and generally could incur liability for the deferred tax and interest charge described above if we receive a distribution from, or sell or otherwise dispose of all or part of our interest in, such lower-tier PFIC, or the U.S. Holder otherwise was deemed to have sold or otherwise disposed of an interest in such lower-tier PFIC. U.S. Holders should consult their tax advisors regarding the application of the lower-tier PFIC rules in their particular circumstances.

A U.S. Holder that owns (or is deemed to own) shares in a PFIC during any taxable year may have to file an IRS Form 8621 (whether or not a QEF election or a mark-to-market election is made) and to provide such other information as may be required by the U.S. Treasury Department. Failure to do so, if required, will extend the statute of limitations applicable to such U.S. Holder until such required information is furnished to the IRS and could result in penalties.

THE PFIC RULES ARE VERY COMPLEX AND U.S. HOLDERS SHOULD CONSULT THEIR TAX ADVISORS REGARDING THE APPLICATION OF SUCH RULES IN THEIR PARTICULAR CIRCUMSTANCES.

### ***Information with Respect to Foreign Financial Assets***

In addition, certain U.S. Holders may be subject to certain reporting obligations with respect to Ordinary Shares if the aggregate value of “specified foreign financial assets” exceeds \$50,000. If required, this disclosure is made by filing Form 8938 with the IRS. Significant penalties can apply if U.S. Holders are required to make this disclosure and fail to do so. In addition, a U.S. Holder should consider the possible obligation for online filing of a FinCEN Report 114—Foreign Bank and Financial Accounts Report as a result of



holding Ordinary Shares. U.S. Holders are thus encouraged to consult their U.S. tax advisors with respect to these and other reporting requirements that may apply to their acquisition of Ordinary Shares.

## [Table of Contents](#)

### ***Information Reporting and Backup Withholding***

In general, information reporting requirements will apply to distributions made on our Ordinary Shares within the U.S. to a non-corporate U.S. Holder and to the proceeds from the sale, exchange, redemption or other disposition of Ordinary Shares by a non-corporate U.S. Holder to or through a U.S. office of a broker. Payments made (and sales or other dispositions effected at an office) outside the U.S. will be subject to information reporting in limited circumstances.

In addition, backup withholding of U.S. federal income tax may apply to such amounts if the U.S. Holder fails to provide an accurate taxpayer identification number (or otherwise establishes, in the manner provided by law, an exemption from backup withholding) or to report dividends required to be shown on the U.S. Holder's U.S. federal income tax returns.

Backup withholding is not an additional tax. The amount of any backup withholding from a payment to a U.S. Holder will be allowed as a credit against the U.S. Holder's U.S. federal income tax liability and may entitle the U.S. Holder to a refund, provided that the required information is timely furnished to the IRS.

U.S. Holders should consult their tax advisors regarding the information reporting requirements and the application of the backup withholding rules in their particular circumstances.

THIS DISCUSSION IS FOR GENERAL INFORMATIONAL PURPOSES ONLY AND IS NOT TAX ADVICE. U.S. HOLDERS SHOULD CONSULT THEIR TAX ADVISORS REGARDING THE U.S. FEDERAL, STATE, AND LOCAL AND NON-U.S. INCOME AND NON-INCOME TAX CONSEQUENCES OF THE ACQUISITION, OWNERSHIP, AND DISPOSITION OF ORDINARY SHARES, INCLUDING THE IMPACT OF ANY POTENTIAL CHANGE IN LAW, IN THEIR PARTICULAR CIRCUMSTANCES.

### **Cayman Islands Tax Considerations**

The following is a discussion on certain Cayman Islands income tax consequences of an investment in the Ordinary Shares. The discussion is a general summary of present law, which is subject to prospective and retroactive change. It is not intended as tax advice, does not consider any investor's particular circumstances, and does not consider tax consequences other than those arising under Cayman Islands law. Prospective investors should consult their professional advisers on the possible tax consequences of buying, holding or selling any shares under the laws of their country of citizenship, residence or domicile.

#### ***Under Existing Cayman Islands Laws:***

Payments of dividends and capital in respect of our Ordinary Shares will not be subject to taxation in the Cayman Islands and no withholding will be required on the payment of interest and principal or a dividend or capital to any holder of Ordinary Shares, as the case may be, nor will gains derived from the disposal of the Ordinary Shares be subject to Cayman Islands income or corporation tax. The Cayman Islands currently have no income, corporation or capital gains tax and no estate duty, inheritance tax or gift tax.

The Company has been incorporated under the laws of the Cayman Islands as an exempted company with limited liability and, as such, has obtained an undertaking from the Governor in Cabinet of the Cayman Islands in the following form:

#### ***The Tax Concessions Law***

##### ***Undertaking as to Tax Concessions***

In accordance with the Tax Concessions Law, the following undertaking is hereby given to the Company:

(a) that no law which is hereafter enacted in the Cayman Islands imposing any tax to be levied on profits, income, gains or appreciations shall apply to its operations; and

(b) in addition, that no tax to be levied on profits, income, gains or appreciations or which is in the nature of estate duty or inheritance tax shall be payable:

(i) on or in respect of the shares, debentures or other obligations of our Company; or

(ii) by way of the withholding in whole or part, of any relevant payment as defined in Tax Concessions Law.

These concessions shall be for a period of TWENTY years from the 18<sup>th</sup> day of July 2023.

The Cayman Islands currently levy no taxes on individuals or corporations based upon profits, income, gains or appreciations and there is no taxation in the nature of inheritance tax or estate duty. There are no other taxes likely to be material to the Company

levied by the Government of the Cayman Islands save certain stamp duties which may be applicable, from time to time, on certain instruments executed in or brought within the jurisdiction of the Cayman Islands.

## [Table of Contents](#)

The Cayman Islands enacted the International Tax Co-operation (Economic Substance) Act (2021 Revision) together with the Guidance Notes published by the Cayman Islands Tax Information Authority from time to time. The Company is required to comply with the economic substance requirements from July 1, 2019 and make an annual report in the Cayman Islands as to whether or not it is carrying on any relevant activities and if it is, it must satisfy an economic substance test.

### **F. Dividends and Paying Agents**

Not applicable.

### **G. Statement by Experts**

Not applicable.

### **H. Documents on Display**

We are subject to certain of the informational filing requirements of the Exchange Act. Since we are a “foreign private issuer,” we are exempt from the rules and regulations under the Exchange Act prescribing the furnishing and content of proxy statements, and our officers, directors and principal shareholders are exempt from the reporting and “short-swing” profit recovery provisions contained in Section 16 of the Exchange Act, with respect to their purchase and sale of our shares. In addition, we are not required to file reports and financial statements with the SEC as frequently or as promptly as U.S. companies whose securities are registered under the Exchange Act. However, we are required to file with the SEC an annual report on Form 20-F containing financial statements audited by an independent accounting firm. We may, but are not required, to furnish to the SEC, on Form 6-K, unaudited financial information after each of our first three fiscal quarters. The SEC also maintains a website at <http://www.sec.gov> that contains reports and other information that we file with or furnish electronically with the SEC. You may read and copy any report or document we file, including the exhibits, at the SEC’s public reference room located at 100 F Street, N.E., Washington, D.C. 20549. Please call the SEC at 1-800-SEC-0330 for further information on the public reference room.

### **I. Subsidiary Information**

Not applicable.

### **J. Annual Report to Security Holders**

Not applicable.

## **ITEM 11. QUANTITATIVE AND QUALITATIVE DISCLOSURES ABOUT MARKET RISK**

### **Credit Risk**

Credit risk is the potential financial loss to us resulting from the failure of a customer or a counterparty to settle our financial and contractual obligations, as and when they fall due. As we do not hold any collateral, the maximum exposure to credit risk is the carrying amounts of trade and other receivables (exclude upfront payments) and cash and bank deposits presented on the consolidated balance sheets. We have no other financial assets which carry significant exposure to credit risk.

### **Foreign Currency Risk**

We operate in several countries and regions, which exposes us to the effects of fluctuations in currency exchange rates as we report our financials and key operational metrics in US dollars. We earn revenue denominated in, and generally incur expenses for employee compensation and other operating expenses in, local currencies. Fluctuations in the exchange rates among the various currencies that we use could cause fluctuations in our operational and financial results.

## **ITEM 12. DESCRIPTION OF SECURITIES OTHER THAN EQUITY SECURITIES**

### ***Warrants***

Information regarding our Warrants is set forth in the Form F-4 under the section titled “Description of PubCo’s Securities — Warrants” and is incorporated herein by reference. Upon the completion of the Business Combination, there were 3,224,994 Warrants outstanding. The Warrants, which entitle the holder to purchase one Ordinary Share at an exercise price of \$11.50 per share, subject to adjustment pursuant to the terms of the Warrant Agreement and Warrant Assumption Agreement, will become exercisable on September 25, 2023, which is 30 days after the completion of the Business Combination. The Warrants will expire on September 25,

2028, (i.e., five years after the completion of the Business Combination) or earlier upon redemption or liquidation in accordance with their terms.

## PART II

### ITEM 13. DEFAULTS, DIVIDEND ARREARAGES AND DELINQUENCIES

Not applicable.

### ITEM 14. MATERIAL MODIFICATIONS TO THE RIGHTS OF SECURITY HOLDERS AND USE OF PROCEEDS

Not applicable.

### ITEM 15. CONTROLS AND PROCEDURES

#### A. Disclosure Controls and Procedures

We maintain disclosure controls and procedures that are designed to ensure that information required to be disclosed in our reports under the Exchange Act is recorded, processed, summarized and reported within the time periods specified in the SEC's rules and forms, and that such information is accumulated and communicated to our management, including our Chief Executive Officer and our Chief Financial Officer, as appropriate, to allow timely decisions regarding required disclosures. Any controls and procedures, no matter how well designed and operated, can provide only reasonable assurance of achieving the desired control objectives. Based upon that evaluation, our management has concluded that, as of June 30, 2023, our disclosure controls and procedures were not effective in ensuring that the information required to be disclosed by us in the reports that we file and furnish under the Exchange Act was recorded, processed, summarized and reported, within the time periods specified in the SEC's rules and forms, and that the information required to be disclosed by us in the reports that we file or submit under the Exchange Act is accumulated and communicated to our management, including our Chief Executive Officer and Chief Financial Officer, to allow timely decisions regarding required disclosure.

#### B. Management's Annual Report on Internal Control over Financial Reporting

This annual Report does not include a report of management's assessment regarding internal control over financial reporting or an attestation report by our independent registered public accounting firm due to a transition period established by rules of the SEC for newly listed public companies.

#### C. Attestation Report of the Registered Public Accounting Firm

This annual Report does not include a report of management's assessment regarding internal control over financial reporting or an attestation report of the company's registered public accounting firm due to a transition period established by rules of the SEC for newly public companies.

#### D. Internal Control Over Financial Reporting

Prior to the closing of the Business Combination, we were a private company with limited numbers of accounting personnel and other resources with which to address our internal controls and procedures. In connection with the audit of our consolidated financial statements for the years ended June 30, 2023 and 2022, we and our auditors, an independent registered public accounting firm, identified one material weakness in our internal control over financial reporting. As defined in the standards established by the PCAOB, a "material weakness" is a deficiency, or combination of deficiencies, in internal control over financial reporting, such that there is a reasonable possibility that a material misstatement of the annual or interim financial statements will not be prevented or detected on a timely basis. A "significant deficiency" is a deficiency, or a combination of deficiencies, in internal control over financial reporting, that is less severe than a material weakness yet important enough to merit attention by those responsible for oversight of the company's financial reporting.

We have started implementing several measures to address this identified material weakness, including: (1) hiring additional accounting and financial reporting personnel with U.S. GAAP and SEC reporting experience, (2) implementing regular and continuous U.S. GAAP accounting and financial reporting training programs for our accounting and financial reporting personnel; and (3) strengthening corporate governance. Because such remediation measures were not fully implemented, our management concluded that the material weakness still existed as of June 30, 2023. We expect to complete the measures discussed above by the June 30, 2024 and will continue to implement measures to remediate our material weakness in order to meet the deadline for management to report on internal controls as required by Section 404 (a) of the Sarbanes Oxley Act.

#### E. Changes in Internal Control over Financial Reporting

Other than as described above, there were no changes in our internal control over financial reporting (as defined in Rules 13a-15(f) or 15d-15(f) of the Exchange Act) that occurred during the period covered by this annual Report that have materially affected, or are reasonably likely to materially affect, the Company's internal control over financial reporting.



**ITEM 16. [RESERVED]**

**ITEM 16A. AUDIT COMMITTEE FINANCIAL EXPERT**

Mr. Timothy Lai Wah Teo is the chairperson of the audit committee, and he satisfies the criteria of an audit committee financial expert as set forth under the applicable rules of the SEC.

**ITEM 16B. CODE OF ETHICS**

We have adopted a Code of Business Conduct and Ethics applicable to our directors, officers and employees. We seek to conduct business ethically, honestly, and in compliance with applicable laws and regulations. Our Code of Business Conduct and Ethics sets out the principles designed to guide our business practices with integrity, respect and dedication. The code applies to all directors, officers, employees and extended workforce, including our directors and executive officers. We expect our suppliers, contractors, consultants, and other business partners to follow the principles set forth in its code when providing goods and services to us or acting on our behalf.

**ITEM 16C. PRINCIPAL ACCOUNTANT FEES AND SERVICES**

**Fees Paid to Independent Public Accountants**

The following table sets forth, for each of the years indicated, the fees billed by Marcum Asia CPAs LLP.

Services	Year Ended June 30,	
	2023	2022
	USD	USD
Audit Fees <sup>(1)</sup>	288,400	252,350

(1) “Audit fees” means the aggregate fees billed in each of the fiscal years listed for professional services rendered by the independent registered public accounting firms for the audit of the annual financial statements and the review of the interim financial information of noco-noco, included in our Form 20-F, registration statements and other required filings with the SEC.

**Pre-Approval Policies and Procedures**

Our Audit Committee has adopted policies and procedures for the pre-approval of audit and non-audit services rendered by our independent registered public accounting firm. Pre-approval of an audit or non-audit service may be given as a general pre-approval, as part of the audit committee’s approval of the scope of the engagement of our independent registered public accounting firm, or on an individual basis. Any proposed services exceeding general pre-approved levels also requires specific pre-approval by our audit committee. The policy prohibits retention of the independent registered public accounting firm to perform the prohibited non-audit functions defined in Section 201 of the Sarbanes-Oxley Act or the rules of the Securities and Exchange Commission, and also requires the audit committee to consider whether proposed services are compatible with the independence of the registered public accounting firm. All of the fees described above were pre- approved by our Audit Committee.

**ITEM 16D. EXEMPTIONS FROM THE LISTING STANDARDS FOR AUDIT COMMITTEES**

Not applicable.

**ITEM 16E. PURCHASES OF EQUITY SECURITIES BY THE ISSUER AND AFFILIATED PURCHASERS**

**Issuer Purchase of Equity Securities**

Neither we, nor any affiliated purchaser of our Company, has purchased any of our securities during the year ended June 30, 2023.

**ITEM 16F. CHANGE IN REGISTRANT’S CERTIFYING ACCOUNTANT**

Not applicable.



## ITEM 16G. CORPORATE GOVERNANCE

### Controlled Company

We are a “controlled company” as defined under the Nasdaq Stock Market Rules because 3DOM Alliance, our majority shareholder, holds more than 50% of our voting power, and we expect we will continue to be a controlled company upon completion of this offering. For so long as we remain a “controlled company,” we are not required to comply with the following permitted to elect to rely, and may rely, on certain exemptions from the obligation to comply with certain corporate governance requirements, including:

- our board of directors is not required to be comprised of a majority of independent directors.
- our board of directors is not subject to the compensation committee requirement; and
- we are not subject to the requirements that director nominees be selected either by the independent directors or a nomination committee comprised solely of independent directors.

As a result, if we take advantage of these exemptions, you will not have the same protections afforded to shareholders of companies that are subject to all of the Nasdaq corporate governance requirements. We intend to take advantage of these controlled company exemptions. As a result, you may not be provided with the benefits of certain corporate governance requirements of Nasdaq applicable to U.S. domestic public companies. See “*Risk Factors — Because we are a “controlled company” as defined in the Nasdaq Stock Market Rules, you may not have protections of certain corporate governance requirements which otherwise are required by Nasdaq’s rules.*”

### Foreign Private Issuer

We are a foreign private issuer as such term is defined in Rule 405 under the Securities Act and are a company incorporated in the Cayman Islands, and, we are a listed company on the Nasdaq. The Nasdaq market rules permit a foreign private issuer like us to follow the corporate governance practices of its home country. Certain corporate governance practices in the Cayman Islands, which is our home country, may differ significantly from the Nasdaq corporate governance listing standards applicable to domestic U.S. companies.

Because we have qualified as a foreign private issuer under the Exchange Act immediately following the consummation of the Business Combination, we are exempt from certain provisions of the securities rules and regulations in the United States that are applicable to U.S. domestic issuers, including: (i) the rules under the Exchange Act requiring the filing of quarterly reports on Form 10-Q and current reports on Form 8-K with the SEC; (ii) the sections of the Exchange Act regulating the solicitation of proxies, consents, or authorizations in respect of a security registered under the Exchange Act; (iii) the sections of the Exchange Act requiring insiders to file public reports of their share ownership and trading activities and liability for insiders who profit from trades made in a short period of time; and (iv) the selective disclosure rules by issuers of material nonpublic information under Regulation FD.

In addition, we are not required to have: (i) a majority of the board of directors consist of independent directors; (ii) a compensation committee consisting of independent directors; (iii) a nominating and corporate committee consisting of independent directors; or (iv) regularly scheduled executive sessions with only independent directors each year.

We intend to rely on some of the exemptions listed above. As a result, you may not be provided with the benefits of certain corporate governance requirements of the Nasdaq applicable to U.S. domestic public companies.

We are required to file an annual report on Form 20-F within four months of the end of each fiscal year. Press releases relating to financial results and material events will also be furnished to the SEC on Form 6-K. However, the information we are required to file with or furnish to the SEC will be less extensive and less timely compared to that required to be filed with the SEC by U.S. domestic issuers. Accordingly, you may receive less or different information about us than you would receive about a U.S. domestic public company.

The determination of foreign private issuer status is made annually on the last business day of an issuer’s most recently completed second fiscal quarter. In the future, we could lose our status as a foreign private issuer under current SEC rules and regulations if more than 50% of our outstanding voting securities become directly or indirectly held of record by U.S. holders and any one of the following is true: (i) the majority of our directors or executive officers are U.S. citizens or residents; (ii) more than 50% of our assets are located in the United States; or (iii) our business is administered principally in the United States. If we lose our status as a foreign private issuer in the future, it will no longer be exempt from the rules described above and, among other things, will be required to file periodic reports and annual and quarterly financial statements as if we were a company incorporated in the United States. If this were to happen, we would likely incur substantial costs in fulfilling these additional regulatory requirements, including costs related to the preparation of financial statements in accordance with U.S. GAAP, and members of our management would likely have to divert time and resources from other responsibilities to ensuring these additional regulatory requirements are fulfilled.



[Table of Contents](#)

**ITEM 16H. MINE SAFETY DISCLOSURE**

Not applicable.

**ITEM 16I. DISCLOSURE REGARDING FOREIGN JURISDICTIONS THAT PREVENT INSPECTIONS**

Not applicable.

**ITEM 16J. INSIDER TRADING POLICIES**

The Company has adopted securities trading policies and procedures governing the purchase, sale, and other dispositions of the group's securities by directors, senior management, and employees that are reasonably designed to promote compliance with applicable insider trading laws, rules and regulations, and any listing standards applicable to the registrant.

## [Table of Contents](#)

### PART III

#### ITEM 17. FINANCIAL STATEMENTS

We have elected to furnish financial statements and related information specified in Item 18.

#### ITEM 18. FINANCIAL STATEMENTS

The financial statements are filed as part of this annual Report beginning on page F-1.

#### ITEM 19. EXHIBITS

##### EXHIBIT INDEX

EXHIBIT NUMBER	DESCRIPTION
1.1	<a href="#">Form of Amended and Restated Memorandum and Articles of Association of the Company, effective on August 25, 2023(incorporated herein by reference to Exhibit 3.5 to Amendment No. 3 to the Registration Statement on Form F-4 (File No. 333-271994), filed with the SEC on July 21, 2023).</a>
2.1*	<a href="#">Specimen Ordinary Share Certificate of the Company.</a>
2.2*	<a href="#">Specimen Warrant Certificate of the Company.</a>
2.3*	<a href="#">Description of Securities Registered under Section 12 of the Securities Exchange Act of 1934</a>
4.1	<a href="#">Business Combination Agreement dated December 29, 2022, by and among PNAC, Prime Number Merger Sub Inc., Noco-Noco Pte. Ltd., and certain other parties of the agreement, joined by PubCo and New SubCo on February 3, 2022 (incorporated herein by reference to Exhibit 2.1 to Amendment No. 3 to the Registration Statement on Form F-4 (File No. 333-271994), filed with the SEC on July 21, 2023).</a>
4.2	<a href="#">Form of Lock-Up Agreement (incorporated herein by reference to Exhibit 10.9 to Amendment No. 3 to the Registration Statement on Form F-4 (File No. 333-271994), filed with the SEC on July 21, 2023).</a>
4.3	<a href="#">Form of Warrant Assumption Agreement, between PNAC, PubCo and VStock Transfer, LLC. (incorporated herein by reference to Exhibit 4.7 to Amendment No. 3 to the Registration Statement on Form F-4 (File No. 333-271994), filed with the SEC on July 21, 2023).</a>
4.4	<a href="#">Form of Registration Rights Agreement (incorporated herein by reference to Exhibit 10.10 to Amendment No. 3 to the Registration Statement on Form F-4 (File No. 333-271994), filed with the SEC on July 21, 2023).</a>
4.5†	<a href="#">2023 Equity Incentive Plan (incorporated herein by reference to Exhibit 10.14 to Amendment No. 3 to the Registration Statement on Form F-4 (File No. 333-271994), filed with the SEC on July 21, 2023).</a>
4.6†	<a href="#">Form of Employment Agreement between the Company and its executive officers (incorporated herein by reference to Exhibit 10.16 to Amendment No. 3 to the Registration Statement on Form F-4 (File No. 333-271994), filed with the SEC on July 21, 2023).</a>
4.7†	<a href="#">Form of Indemnification Agreement between the Company's and its executive officers (incorporated herein by reference to Exhibit 10.18 to Amendment No. 3 to the Registration Statement on Form F-4 (File No. 333-271994), filed with the SEC on July 21, 2023).</a>
4.8*	<a href="#">Forward Purchase Agreement by and among Prime Number Acquisition I Corp., NOCO-NOCO PTE. LTD., Meteora Select Trading Opportunities Master, LP, Meteora Capital Partners, LP and Meteora Strategic Capital, LLC dated August 13, 2023.</a>

- 4.9 [Forward Purchase Agreement Confirmation Amendment by and among the Company, NOCO-NOCO PTE. LTD., Meteora Select Trading Opportunities Master, LP, Meteora Capital Partners, LP and Meteora Strategic Capital, LLC dated October 26, 2023 \(incorporated herein by reference to Exhibit 10.1 to a Current Report on Form 6-K \(File No. 001-41789\), filed with the SEC on October 30, 2023\).](#)

## Table of Contents

<b>EXHIBIT NUMBER</b>	<b>DESCRIPTION</b>
4.10	<a href="#"><u>Purchase Agreement by and between the Company and Arena Business Solutions Global SPC II, Ltd, dated August 14, 2023 (incorporated herein by reference to Exhibit 10.4 to the Registration Statement on Form F-1 (File No. 333-271994), filed with the SEC on September 19, 2023).</u></a>
4.11	<a href="#"><u>Amendment No.1 to the Purchase Agreement by and between the Company and Arena Business Solutions Global SPC II, Ltd, dated September 18, 2023 (incorporated herein by reference to Exhibit 10.5 to the Registration Statement on Form F-1 (File No. 333-271994), filed with the SEC on September 19, 2023).</u></a>
4.12	<a href="#"><u>Payoff Letter among the Company, Prime Number Acquisition I Corp., Prime Number Capital LLC and WestPark Capital, Inc. dated October 10, 2023 (incorporated herein by reference to Exhibit 10.1 to a Current Report on Form 6-K (File No. 333-271994), filed with the SEC on October 12, 2023).</u></a>
8.1	<a href="#"><u>List of significant subsidiaries of the Company (incorporated herein by reference to Exhibit 21.1 to Amendment No. 3 to the Registration Statement on Form F-4 (File No. 333-271994), filed with the SEC on July 21, 2023).</u></a>
11.1	<a href="#"><u>Code of Business Conduct and Ethics of the Company (incorporated herein by reference to Exhibit 14.1 to Amendment No. 3 to the Registration Statement on Form F-4 (File No. 333-271994), filed with the SEC on July 21, 2023).</u></a>
11.2	<a href="#"><u>Form of Insider Trading Policy (incorporated herein by reference to Exhibit 19.1 to Amendment No. 3 to the Registration Statement on Form F-4 (File No. 333-271994), filed with the SEC on July 21, 2023).</u></a>
12.1*	<a href="#"><u>Certification of Principal Executive Officer pursuant to Section 302 of the Sarbanes-Oxley Act of 2002.</u></a>
12.2*	<a href="#"><u>Certification of Principal Financial Officer pursuant to Section 302 of the Sarbanes-Oxley Act of 2002.</u></a>
13.1*	<a href="#"><u>Certification of Principal Executive Officer pursuant to Section 906 of the Sarbanes-Oxley Act of 2002.</u></a>
13.2*	<a href="#"><u>Certification of Principal Financial Officer pursuant to Section 906 of the Sarbanes-Oxley Act of 2002.</u></a>
15.1*	<a href="#"><u>Consent of Ogier.</u></a>
15.2*	<a href="#"><u>Consent of Greenhalgh Pickard.</u></a>
15.3*	<a href="#"><u>Consent of Icon Law LLC.</u></a>

---

\* Filed herewith.

† Indicates a management contract or any compensatory plan, contract or arrangement.

**SIGNATURE**

The registrant hereby certifies that it meets all of the requirements for filing on Form 20-F and that it has duly caused and authorized the undersigned to sign this report on its behalf.

**noco-noco Inc.**

November 14, 2023

By

: /s/ Masataka Matsumura

Name

: Masataka Matsumura

Title: Director and CEO

[Table of Contents](#)

**INDEX TO FINANCIAL STATEMENTS**

	<b><u>Page</u></b>
<a href="#">Report of Independent Registered Public Accounting Firm (PCAOB ID: 5395)</a>	<b>F-2</b>
<a href="#">Balance Sheets as of June 30, 2023 and 2022</a>	<b>F-3</b>
<a href="#">Consolidated Statements of Operations and Comprehensive Loss for the Fiscal Years Ended June 30, 2023 and 2022</a>	<b>F-4</b>
<a href="#">Consolidated Statements of Changes in Shareholders' Equity (Deficit) as of June 30, 2023 and 2022</a>	<b>F-5</b>
<a href="#">Consolidated Statements of Cash Flows for the Fiscal Year Ended June 30, 2023 and 2022</a>	<b>F-6</b>
<a href="#">Notes to the Financial Statements</a>	<b>F-7</b>



# MARCUMASIA

## REPORT OF INDEPENDENT REGISTERED PUBLIC ACCOUNTING FIRM

To the Shareholders and Board of Directors of noco-noco Inc.

### Opinion on the Financial Statements

We have audited the accompanying consolidated balance sheets of noco-noco Inc. (the "Company") as of June 30, 2023 and 2022, the related consolidated statements of operations and comprehensive loss, stockholders' equity and cash flows for each of the two years in the period ended June 30, 2023, and the related notes (collectively referred to as the "financial statements"). In our opinion, the financial statements present fairly, in all material respects, the financial position of the Company as of June 30, 2023 and 2022, and the results of its operations and its cash flows for each of the two years in the period ended June 30, 2023, in conformity with accounting principles generally accepted in the United States of America.

### Explanatory Paragraph – Going Concern

The accompanying financial statements have been prepared assuming that the Company will continue as a going concern. As more fully described in Note 2, the Company has incurred significant losses and needs to raise additional funds to meet its obligations and sustain its operations. This condition raises substantial doubt about the Company's ability to continue as a going concern. Management's plans in regard to these matters are also described in Note 2. The financial statements do not include any adjustments that might result from the outcome of this uncertainty.

### Basis for Opinion

These financial statements are the responsibility of the Company's management. Our responsibility is to express an opinion on the Company's financial statements based on our audits. We are a public accounting firm registered with the Public Company Accounting Oversight Board (United States) ("PCAOB") and are required to be independent with respect to the Company in accordance with the U.S. federal securities laws and the applicable rules and regulations of the Securities and Exchange Commission and the PCAOB.

We conducted our audits in accordance with the standards of the PCAOB. Those standards require that we plan and perform the audits to obtain reasonable assurance about whether the financial statements are free of material misstatement, whether due to error or fraud. The Company is not required to have, nor were we engaged to perform, an audit of its internal control over financial reporting. As part of our audits we are required to obtain an understanding of internal control over financial reporting but not for the purpose of expressing an opinion on the effectiveness of the Company's internal control over financial reporting. Accordingly, we express no such opinion.

Our audits included performing procedures to assess the risks of material misstatement of the financial statements, whether due to error or fraud, and performing procedures that respond to those risks. Such procedures included examining, on a test basis, evidence regarding the amounts and disclosures in the financial statements. Our audits also included evaluating the accounting principles used and significant estimates made by management, as well as evaluating the overall presentation of the financial statements. We believe that our audits provide a reasonable basis for our opinion.

/s/ Marcum Asia CPAs LLP

---

**Marcum Asia CPAs LLP**

We have served as the Company's auditor since 2022.

**New York**  
**November 14, 2023**



**NOCO-NOCO GROUP AND SUBSIDIARIES**  
**CONSOLIDATED BALANCE SHEETS**  
(Amounts expressed in US dollars (“\$”) except for numbers of shares)

	<u>June 30, 2023</u>	<u>June 30, 2022</u>
<b>ASSETS</b>		
<b>Current assets</b>		
Cash and cash equivalents	\$ 17,789	\$ 81,626
Deposit, upfront payments and other receivables	104,560	102,263
Promissory note – Prime Number Acquisition I Corp.	333,594	—
<b>Total current assets</b>	<u>455,943</u>	<u>183,889</u>
<b>Non-current assets</b>		
Property and equipment, net	14,991	10,607
Right of use assets – operating lease, net	220,261	44,925
<b>Total assets</b>	<u>\$ 691,195</u>	<u>\$ 239,421</u>
<b>Liabilities and Shareholders' (Deficit) Equity</b>		
<b>Current liabilities</b>		
Accruals and other payables	\$ 587,346	\$ 13,227
Operating lease liability – current	173,045	36,385
<b>Total current liabilities</b>	<u>760,391</u>	<u>49,612</u>
<b>Non-current liabilities</b>		
Amount due to immediate holding company	3,572,358	974,632
Operating lease liability – non-current	36,700	—
<b>Total liabilities</b>	<u>\$ 4,369,449</u>	<u>\$ 1,024,244</u>
<b>Shareholders' equity</b>		
Ordinary stock (\$0.0001 par value, 126,799,854 and 121,432,144 shares issued and outstanding as of June 30, 2023 and 2022, respectively) *	\$ 12,679	\$ 12,143
Additional paid in capital	15,903,549	1,545,661
Accumulated deficit	(19,143,513)	(2,351,743)
Accumulated other comprehensive income	(451,038)	9,116
<b>Total noco-noco Inc. shareholders' equity</b>	<u>\$ (3,678,323)</u>	<u>\$ (784,823)</u>
Non-controlling interest	69	—
<b>Total shareholders' equity</b>	<u>(3,678,254)</u>	<u>(784,823)</u>
<b>Total liabilities and shareholder's equity</b>	<u>\$ 691,195</u>	<u>\$ 239,421</u>

\* Shares and per share data are presented on a retroactive basis to give effect to the reverse recapitalization.

The accompanying notes are an integral part of these financial statements.

**NOCO-NOCO GROUP AND SUBSIDIARIES**  
**CONSOLIDATED STATEMENTS OF OPERATIONS AND COMPREHENSIVE LOSS**

	<u>June 30, 2023</u>	<u>June 30, 2022</u>
<b>Operating expenses:</b>		
Research and development	\$ —	\$ 137,412
Selling, general and administrative expenses	16,840,854	951,239
<b>Total operating expenses</b>	<u>16,840,854</u>	<u>1,088,651</u>
<b>Loss from operations</b>	(16,840,854)	(1,088,651)
<b>Other income/(expense):</b>		
Other income	36,439	11,792
Other expense	(256)	—
Foreign exchange gain	12,901	36
<b>Total other income</b>	<u>49,084</u>	<u>11,828</u>
<b>Net loss</b>	(16,791,770)	(1,076,823)
<b>Other comprehensive (loss)/income:</b>		
Foreign currency translation adjustment	(460,152)	(14,143)
<b>Comprehensive loss</b>	<u>(17,251,922)</u>	<u>(1,090,966)</u>
Basic and diluted loss per ordinary share	<u>\$ (0.14)</u>	<u>\$ (0.01)</u>
Basic and diluted weighted average number of ordinary shares outstanding	<u>123,964,463</u>	<u>83,748,856</u>

The accompanying notes are integral to these financial statements.

**NOCO-NOCO GROUP AND SUBSIDIARIES**  
**CONSOLIDATED STATEMENTS OF CHANGES IN SHAREHOLDERS' EQUITY (DEFICIT)**

	Ordinary shares		Additional Paid in Capital*	Accumulated Other	Accumulated Deficit	Non- controlling Interest	Total
	Number of shares	Amount*		Comprehensive Income (Loss)			
<b>Balance as of June 30, 2021</b>	<b>779,510</b>	<b>\$ 78</b>	<b>\$ 9,922</b>	<b>\$ 23,259</b>	<b>\$ (1,274,920)</b>	<b>\$ —</b>	<b>\$ (1,241,661)</b>
Ordinary shares issued for conversion of debt	120,652,634	12,065	1,535,739	—	—	—	1,547,804
Foreign currency translation adjustment	—	—	—	(14,143)	—	—	(14,143)
Net loss	—	—	—	—	(1,076,823)	—	(1,076,823)
<b>Balance as of June 30, 2022</b>	<b>121,432,144</b>	<b>\$ 12,143</b>	<b>\$ 1,545,661</b>	<b>\$ 9,116</b>	<b>\$ (2,351,743)</b>	<b>\$ —</b>	<b>\$ (784,823)</b>
Capital contribution from non-controlling interest	—	—	—	(2)	—	69	67
Ordinary shares issued for conversion of debt	295,824	29	790,258	—	—	—	790,287
Share issued under stock-based compensation	5,071,886	507	13,567,630	—	—	—	13,568,137
Foreign currency translation adjustment	—	—	—	(460,152)	—	—	(460,152)
Net loss	—	—	—	—	(16,791,770)	—	(16,791,770)
<b>Balance as of June 30, 2023</b>	<b>126,799,854</b>	<b>\$ 12,679</b>	<b>\$ 15,903,549</b>	<b>\$ (451,038)</b>	<b>\$ (19,143,513)</b>	<b>\$ 69</b>	<b>\$ (3,678,254)</b>

\* Shares and per share data are presented on a retroactive basis to give effect to the reverse recapitalization.

The accompanying notes are integral to these financial statements.

**NOCO-NOCO GROUP AND SUBSIDIARIES**  
**CONSOLIDATED STATEMENTS OF CASH FLOWS**

	June 30, 2023	June 30, 2022
<b>Cash flows from operating activities</b>		
Net loss	\$ (16,791,770)	\$ (1,076,823)
Adjustments for reconcile net loss to net cash used in operating activities:		
Depreciation	4,855	3,447
Stock-based compensation	13,568,137	—
Loss on disposal of property and equipment	256	—
Changes in operating assets and liabilities:		
Inventories	—	163,259
Deposit, upfront payments and other receivables	(2,805)	(18,878)
Accruals and other payables	574,119	121,253
Due from promissory note	(333,594)	—
Operating lease liabilities	(1,976)	2,565
<b>Net cash used in operations</b>	<u>(2,982,778)</u>	<u>(805,177)</u>
<b>Cash flows from investing activities</b>		
Purchase of property and equipment	(5,735)	(3,888)
<b>Cash used in investing activities</b>	<u>(5,735)</u>	<u>(3,888)</u>
<b>Cash flows from financing activities</b>		
Capital contribution from non-controlling interest	67	—
Proceeds from immediate holding company	3,388,520	873,066
<b>Cash generated from financing activities</b>	<u>3,388,587</u>	<u>873,066</u>
Increase/(decrease) in cash and cash equivalents	400,074	64,001
Effect of exchange rate changes	(463,911)	(14,065)
Cash and cash equivalents at beginning of period	81,626	31,690
Cash and cash equivalents at end of period	<u>\$ 17,789</u>	<u>\$ 81,626</u>
<b>Supplemental cash flow information:</b>		
<b>Cash paid during the period for:</b>		
Interest	\$ —	\$ —
<b>Supplemental disclosure of non-cash investing and financing information:</b>		
Issuance of ordinary shares for conversion of debt	<u>\$ 790,287</u>	<u>\$ 1,547,804</u>

The accompanying footnotes are an integral part of these financial statements.

**NOCO-NOCO GROUP AND SUBSIDIARIES**  
**NOTES TO THE CONSOLIDATED FINANCIAL STATEMENTS**  
**JUNE 30, 2023 and 2022**  
**(Amounts expressed in US dollars (“\$”) except for numbers of shares)**

**NOTE 1 – ORGANIZATION AND NATURE OF OPERATIONS**

The Company incorporated as a Singapore corporation on July 25, 2019 under the name 3DOM (Singapore) Pte. Ltd. The Company is wholly owned by 3DOM Alliance Inc., a Company incorporated in Japan and the ultimate controlling shareholder is Mr. Masataka Matsumara.

On November 9, 2022, the Company changed its name from 3DOM (Singapore) Pte. Ltd. to noco-noco Pte. Ltd.

noco-noco Inc. (“we”, “our”, “us” or collectively known as the “Company”) is a platform-solution provider of decarbonization offerings, aiming to truly solve urgent environmental crises through the comprehensive decarbonization of all forms of transportation.

**Reverse Capitalization**

On August 25, 2023 (the “Closing Date”), noco-noco Inc., an exempted company with limited liability incorporated under the laws of the Cayman Islands (the “Company” or “PubCo”), consummated the previously announced Business Combination (defined below).

On December 29, 2022, PubCo, Prime Number Acquisition I Corp. (“PNAC”), Prime Number Merger Sub Inc., a Delaware corporation and a direct wholly-owned subsidiary of PubCo (“Merger Sub”), Prime Number New Sub Pte. Ltd., a Singapore private company limited by shares and a direct wholly-owned subsidiary of PubCo (“New SubCo”), noco-noco Pte. Ltd., a Singapore private company limited by shares (“noco-noco”), and certain shareholders of noco-noco collectively holding a controlling interest (together with other shareholders of noco-noco subsequently joining the transactions, the “Sellers”), entered into a business combination agreement (“Business Combination Agreement”), pursuant to which, PNAC proposed to enter into a business combination with noco-noco involving a merger and a share exchange, among which: (i) Merger Sub would merge with and into PNAC, with PNAC as the surviving entity and a wholly-owned subsidiary of PubCo (the “Merger”), (ii) New SubCo would acquire all of the issued and outstanding shares of noco-noco from the Sellers, and in exchange, PubCo would issue to the Sellers the ordinary shares of PubCo, with noco-noco becoming a subsidiary of New SubCo and an indirect subsidiary of PubCo (the “Share Exchange”, and together with the Merger and the other transactions contemplated by the Business Combination Agreement, the “Business Combination”).

Upon the consummation of the Business Combination, each of PNAC and noco-noco would become a subsidiary of PubCo, and PNAC stockholders and the Sellers would receive ordinary shares, par value \$0.0001 per share, of PubCo (“PubCo Ordinary Shares”) as consideration and become the shareholders of PubCo. The Merger was consummated on August 24, 2023, and the Share Exchange and Business Combination were consummated on the Closing Date.

Pursuant to the Business Combination Agreement, upon the consummation of the Business Combination: (i) each PNAC unit (“PNAC Units”) issued and outstanding immediately prior to the effective time of the Merger was automatically detached and the holder thereof was deemed to hold one share of PNAC Class A Common Stock (defined below), one half of PNAC Warrant (defined below), and one PNAC Right (defined below); (ii) each share of PNAC Class A common stock, par value \$0.0001 per share (“PNAC Class A Common Stock”, together with PNAC Class B Common Stock, par value \$0.0001 per share, the “PNAC Common Stock”) issued and outstanding immediately prior to the effective time of the Merger was canceled in exchange for the right to receive one PubCo Ordinary Share, (iii) each PNAC warrant (“PNAC Warrant”) outstanding immediately prior to the effective time of the Merger ceased to be a warrant with respect to PNAC Common Stock and was assumed by PubCo and converted into a warrant of PubCo (“PubCo Warrant”) to purchase one PubCo Ordinary Share subject to substantially the same terms and conditions prior to the effective time of the Merger; and (iv) each PNAC Right (“PNAC Right”) outstanding immediately prior to the effective time of the Merger was cancelled in exchange for the right to receive one-eighth (1/8) of one PubCo Ordinary Share. In addition, pursuant to the Business Combination Agreement, upon the consummation of the Share Exchange (i) New SubCo acquired all the outstanding shares of noco-noco (“noco-noco Shares”) from the Sellers, (ii) in exchange, each Seller received such number of newly issued PubCo Ordinary Share that was equal to the product of (a) the quotient of (i) \$1,350,000,000 (the “noco-noco Valuation”), divided by (ii) the price per PubCo Ordinary Share that equals to the redemption price of each share of PNAC Class A Common Stock in connection with the Business Combination (the “PubCo Per Share Price”), multiplied by (b) such Seller’s Pro Rata Portion as set out in the Allocation Schedule of the Business Combination Agreement.

The Company was determined to be the accounting acquirer given that the original shareholders of noco-noco Group effectively controlled the combined entity after the Transaction. PNAC is treated as the acquired company for financial reporting purposes. This determination is primarily based on the fact that subsequent to the SPAC Transaction, the Company’s shareholders have a majority of the voting power of the combined company, the Company comprised all of the ongoing operations of the combined entity, the

Company comprised a majority of the governing body of the combined company, and the Company's senior management comprised all of the senior management of the combined company. Accordingly, for accounting purposes, the SPAC Transaction is



## [Table of Contents](#)

accounted for as a reverse recapitalization, which is equivalent to the issuance of shares by the Company for the net assets of PNAC, accompanied by a recapitalization. The Company is determined as the predecessor, and the historical financial statements of noco-noco Group became the Company's historical financial statements, with retrospective adjustments to give effect of the reverse recapitalization. The share and per share data is retrospectively restated to give effect to the reverse recapitalization. Net assets of PNAC were stated at historical costs. No goodwill or other intangible assets were recorded. Operations prior to the SPAC Transaction were those of the noco-noco Group.

### **NOTE 2 – LIQUIDITY AND GOING CONCERN**

As of June 30, 2023 and 2022, the Company had an accumulated deficit of \$19,143,513 and \$2,351,743 respectively. The Company incurred net loss of \$16,791,770 and \$1,076,823 for the financial years ended June 30, 2023 and 2022, respectively. The cash used in operating activities for the financial year ended June 30, 2023 and 2022, was \$2,982,778 and \$805,177, respectively. These conditions raise substantial doubt about the Company's ability to continue as a going concern.

The Company's liquidity is based on its ability to generate cash from operating activities, obtain capital financing from equity interest investors and borrow funds on favorable economic terms to fund its general operations and capital expansion needs. The Company's ability to continue as a going concern is dependent on management's ability to successfully execute its business plan, which includes increasing revenue while controlling operating cost and expenses to generate positive operating cash flows and obtaining funds from outside sources of financing to generate positive financing cash flows. As of June 30, 2023, the Company's balance of cash and cash equivalents was \$17,789. In addition, up to June 30, 2023, the immediate holding Company, 3DOM Alliance Inc, has extended the Promissory Note for the Company with a principal amount up to \$6,022,258 (S\$8,000,000) and the Company has drawdown of \$3,572,358 (S\$4,809,164) from 3DOM Alliance Inc. Moreover, 3DOM Alliance Inc will not demand for payment on the amounts owing by the Company for at least the next twelve months from the issuance of the financial statements.

Furthermore, on August 14, 2023, PubCo entered into a purchase agreement with Arena Business Solutions Global SPC II, Ltd. ("Arena") as amended from time to time, (the "Purchase Agreement"), pursuant to which, PubCo have the right to sell to Arena up to \$150,000,000 of PubCo's Ordinary Shares, subject to certain limitations and conditions set forth in the Purchase Agreement, from time to time during the 36-month term of the Purchase Agreement. However, it is uncertain how much can be raised from the new share issuances to Arena in the next twelve months, as it is dependent on the PubCo's Ordinary Shares daily trading volumes and transacted prices.

There is no assurance that the plans will be successfully implemented. If the Company fails to achieve these goals, the Company may need additional financing to repay debt obligations and execute its business plan, and the Company may not be able to obtain the necessary additional capital on a timely basis, on acceptable terms, or at all. In the event that financing sources are not available, or that the Company is unsuccessful in increasing its gross profit margin and reducing operating losses, the Company may be unable to implement its current plans for expansion, repay debt obligations or respond to competitive pressures, any of which would have a material adverse effect on the Company's business, financial condition and results of operations and may materially adversely affect its ability to continue as a going concern.

The financial statements do not include any adjustments related to the recoverability and classification of recorded assets or the amounts and classification of liabilities or any other adjustments that might be necessary should the Company be unable to continue as a going concern.

The financial statements have been prepared on a going concern basis, which contemplates the realization of assets and the satisfaction of liabilities in the normal course of business. The realization of assets and the satisfaction of liabilities in the normal course of business are dependent on, among other things, the Company's ability to operate profitably, to generate cash flows from operations, and to pursue financing arrangements to support its working capital requirements.

## [Table of Contents](#)

### **NOTE 3 – SUMMARY OF SIGNIFICANT ACCOUNTING POLICIES**

#### **Basis of Presentation**

Our financial statements have been prepared in conformity with U.S. generally accepted accounting principles (“GAAP”) in U.S. dollars. We have made all the adjustments that we believe are necessary for a fair presentation of our financial statements.

#### **Use of estimates**

The preparation of the financial statements in conformity with US GAAP requires management of the Company to make a number of estimates and assumptions relating to the reported amounts of assets and liabilities and the disclosure of contingent assets and liabilities at the date of the financial statements and the reported amounts of revenues and expenses during the reporting period. On an on-going basis we review our estimates and assumptions. The estimates were based on historical experience and other assumptions that we believe to be reasonable under the circumstances. Actual results could differ from those estimates under different assumptions or conditions, but we do not believe such differences will materially affect our financial position or results of operations.

#### **Fiscal Year End**

The Company operates on a fiscal year basis with the fiscal year ending on June 30.

#### **Cash and Cash Equivalents**

Cash and cash equivalents consist of cash on hand and demand deposit with banks, which are unrestricted as to withdrawal and use, and which have original maturities of three months or less when purchased.

#### **Deposit, upfront payments and other receivables**

Security deposits paid for office lease are accounted for as deposits. Amounts paid in advance for future expenses are accounted for as prepaid expenses. Goods and Service Tax (“GST”) refunds are accounted for as other receivables. We expect that the result of adopting current expected credit loss model (“CECL”) is immaterial to other receivables.

#### **Promissory Note – Prime Number Acquisition I Corp.**

During the year, the Company agreed to loan Prime Number Acquisition I Corp. an aggregate of \$333,594 to be used for a portion of the expenses of the Business Combination. These loans are non-interest bearing, unsecured and are due at the closing of the Business Combination.

#### **Property and equipment**

Property and equipment are stated at cost, less accumulated depreciation. Expenditures for additions, major renewals and betterments are capitalized and expenditures for maintenance and repairs are charged to expense as incurred.

Depreciation is computed using the straight-line method over the estimated useful lives of the related capitalized assets. The estimated useful lives are as follows:

	<u>Useful lives</u>
Office equipment	5 years

#### **Other current liabilities**

Other current liabilities are liabilities for goods and services provided to the Company prior to the end of the financial year which are unpaid. They are classified as current liabilities if payment is due within one year or less. If not, they are presented as non-current liabilities.

#### **Deferred Tax Asset Allowance**

Deferred tax assets are recognized for tax losses not yet used and temporary deductible differences. As those deferred tax assets can only be recognized to the extent that it is probable that future taxable profit will be available against which the unused tax credits can be utilized, management’s judgement is required to assess the probability of future taxable profits. Management’s assessment is

constantly reviewed and additional deferred tax assets are recognized if it becomes probable that future taxable profits will allow the deferred tax asset to be recovered.

## [Table of Contents](#)

### **Share-based compensation transaction**

The Company measures the cost of equity-settled transactions by reference to the fair value of the equity instruments at the date at which they are granted. Estimating fair value for share-based compensation transactions requires determining the most appropriate valuation model, which is dependent on the terms and conditions of the grant. This estimate also requires determining the most appropriate inputs to the valuation model including the expected life of the stock option, volatility and dividend yield and making assumptions about them. The fair value of the ordinary shares was determined by obtaining quoted prices over-the-counter market based on the latest transacted price of the Company shares that were sold.

### **Leases**

We have entered into operating lease agreements primarily for office. We determine if an arrangement is a lease at inception. For all classes of underlying assets, we elect not to recognize right of use assets or lease liabilities when a lease has a lease term of 12 months or less at the commencement date and does not include an option to purchase the underlying asset that we are reasonably certain to exercise. Operating lease assets and liabilities are included on our balance sheet as of June 30, 2023 and 2022.

Operating lease assets and liabilities are recognized at the present value of the future lease payments at the lease commencement date. The interest rate used to determine the present value of the future lease payments is our incremental borrowing rate, because the interest rate implicit in most of our leases is not readily determinable. Our incremental borrowing rate is estimated to approximate the interest rate on a collateralized basis with similar terms and payments, and in economic environments where the leased asset is located. Operating lease assets also include any prepaid lease payments and lease incentives. Our lease terms include periods under options to extend or terminate the lease when it is reasonably certain that we will exercise that option. We generally use the base, non-cancellable, lease term when determining the lease assets and liabilities. Operating lease expense is recognized on a straight-line basis over the lease term.

### **Revenue Recognition**

Revenue is recognized when a customer obtains control of promised goods or services and is recognized in an amount that reflects the consideration that an entity expects to receive in exchange for those goods or services. In addition, the standard requires disclosure of the nature, amount, timing, and uncertainty of revenue and cash flows arising from contracts with customers. The Company does not disaggregate its revenue streams as the economic factors underlying the contracts are similar and provide no significant distinction. The amount of revenue that is recorded reflects the consideration that the Company expects to receive in exchange for those goods or services. The Company applies the following five-step model in order to determine this amount: (i) identification of the promised goods or services in the contract; (ii) determination of whether the promised goods or services are performance obligations, including whether they are distinct in the context of the contract; (iii) measurement of the transaction price, including the constraint on variable consideration; (iv) allocation of the transaction price to the performance obligations; and (v) recognition of revenue when (or as) the Company satisfies each performance obligation.

The Company only applies the five-step model to contracts when it is probable that the entity will collect the consideration it is entitled to in exchange for the goods or services it transfers to the customer. Once a contract is determined to be within the scope of ASC 606 at contract inception, the Company reviews the contract to determine which performance obligations the Company must deliver and which of these performance obligations are distinct. The Company recognizes as revenues the amount of the transaction price that is allocated to the respective performance obligation when (or as) the performance obligation is satisfied.

### **Comprehensive Gain or Loss**

ASC 220 “Comprehensive Income,” establishes standards for the reporting and display of comprehensive income and its components in the financial statements. As of June 30, 2023 and 2022, the Company established that there are items that represented components of comprehensive income and, therefore, has included a statement of operations and comprehensive loss in the financial statements.

### **Income Taxes**

The Company utilizes ASC Topic 740, “Income Taxes,” which requires the recognition of deferred tax assets and liabilities for the expected future tax consequences of events that have been included in the financial statements or tax returns. The Company accounts for income taxes using the asset and liability method to compute the differences between the tax basis of assets and liabilities and the related financial amounts, using enacted tax rates expected to apply to taxable income in the years in which those temporary differences are expected to be recovered or settled. The effect on deferred tax assets and liabilities of a change in tax rates is recognized in income in the period including the enactment date. Valuation allowances are established, when necessary, to reduce deferred tax assets to the amount expected to be realized. Current income taxes are provided for in accordance with the laws of the relevant taxing authorities. A valuation allowance is recorded when it is “more likely-than-not” that a deferred tax asset will not be realized.



## [Table of Contents](#)

FASB ASC 740 prescribes a recognition threshold and a measurement attribute for the financial statement recognition and measurement of tax positions taken or expected to be taken in a tax return. For those benefits to be recognized, a tax position must be more likely than not to be sustained upon examination by taxing authorities. The Company's practice is to recognize interest and penalties, if any, related to uncertain tax positions in income tax expense in the statements of operations and comprehensive loss. There were no unrecognized tax benefits as of June 30, 2023 and 2022.

### **Measurement of Fair Value**

The fair value of a financial instrument is the amount that could be received upon the sale of an asset or paid to transfer a liability in an orderly transaction between market participants at the measurement date. Financial assets are marked to bid prices and financial liabilities are marked to offer prices. Fair value measurements do not include transaction costs. A fair value hierarchy is used to prioritize the quality and reliability of the information used to determine fair values. Categorization within the fair value hierarchy is based on the lowest level of input that is significant to the fair value measurement. The fair value hierarchy is defined in the following three categories:

Level 1: applies to assets or liabilities for which there are quoted prices in active markets for identical assets or liabilities.

Level 2: applies to assets or liabilities for which there are inputs other than quoted prices included within Level 1 that are observable for the asset or liability such as quoted prices for similar assets or liabilities in active markets; quoted prices for identical assets or liabilities in markets with insufficient volume or infrequent transactions (less active markets); or model-derived valuations in which significant inputs are observable or can be derived principally from, or corroborated by, observable market data.

Level 3: applies to assets or liabilities for which there are unobservable inputs to the valuation methodology that are significant to the measurement of the fair value of the assets or liabilities.

At June 30, 2023 and 2022, the Company has no financial assets or liabilities subject to recurring fair value measurements.

The Company's financial instruments include cash, upfront payments, other receivables, other payables and related payables. Management estimates that the carrying amounts of financial instruments approximate their fair values due to their short-term nature. The fair value of amounts with immediate holding company is not practicable to estimate due to the related party nature of the underlying transactions.

### **Net Loss Per Share**

The Company has adopted ASC Topic 260, "*Earnings per Share*," ("EPS") which requires presentation of basic EPS on the face of the income statement for all entities with complex capital structures and requires a reconciliation of the numerator and denominator of the basic EPS computation. In the accompanying financial statements, basic earnings per share is computed by dividing net loss by the weighted average number of shares of ordinary shares outstanding during the period.

For the periods ended June 30, 2023, and 2022, the ordinary shares were included in the computation of diluted net loss per share.

### **Accumulated Other Comprehensive Income/(Loss)**

Unrealized gains and losses related to foreign currency translation are accumulated in "Accumulated other comprehensive loss" ("AOCI"). These changes are also reported in "Other comprehensive income (loss)" on the Condensed Consolidated Statements of Comprehensive Income.

### **Foreign Currency Translation**

The functional currency of the Company is the currency of the primary economic environment in which the Company operates. Assets and liabilities denominated in currencies other than the functional currency are remeasured using the current exchange rate for monetary accounts and historical exchange rates for nonmonetary accounts, with exchange differences on remeasurement included in comprehensive income in our Statements of Comprehensive Income.

The Company that utilizes foreign currency as their functional currency translate such currency into U.S. dollars using (i) the exchange rate on the balance sheet dates for assets and liabilities, (ii) the average exchange rates prevailing during the period for revenues and expenses, and (iii) historical exchange rates for equity. Any translation adjustments resulting from this process are shown separately as a component of accumulated other comprehensive loss within shareholders' deficit in Balance Sheets.

### **Comparative Information**

Certain items in prior years consolidated financial statements have been reclassified to conform to the current period's presentation to facilitate comparison..

### **Recent Accounting Pronouncements**

In June 2016, the FASB issued ASU No. 2016-13, Financial Instruments – Credit Losses (Topic 326), Measurement of Credit Losses on Financial Instruments. This standard requires a financial asset (or group of financial assets) measured at amortized cost basis to be presented at the net amount expected to be collected. The allowance for credit losses is a valuation account that is deducted from the amortized cost basis of the financial asset(s) to present the net carrying value at the amount expected to be collected on the financial asset. We adopted the new standard effective January 1, 2023 and the adoption of this guidance did not have a material impact on our financial statements.

In December 2019, the Financial Accounting Standards Board (FASB) issued Accounting Standard Update No. 2019-12, Income Taxes (Topic 740): Simplifying the Accounting for Income Taxes (ASU 2019-12), which simplifies the accounting for income taxes. This guidance will be effective for entities for the fiscal years, and interim periods within those fiscal years, beginning after December 15, 2020 on a prospective basis, with early adoption permitted. We adopted the new standard effective January 1, 2021 and the adoption of this guidance did not have a material impact on our financial statements.

We do not expect any other recently issued accounting standards to have a material impact on our financial position, results of operations or cash flows when they become effective.

## [Table of Contents](#)

### NOTE 4 – DEPOSIT, UPFRONT PAYMENTS AND OTHER RECEIVABLES

Deposit, upfront payments and other receivables consists of the following:

	June 30, 2023	June 30, 2022
Deposits	\$ 45,369	\$ 44,971
Upfront payments	47,161	51,840
Other receivables	12,030	5,452
Total	<u>\$ 104,560</u>	<u>\$ 102,263</u>

Deposit consists of the security deposit paid for lease of office, increased mainly due to foreign exchange.

Upfront payments as of June 30, 2023 and 2022 relates to the operating expenses paid in advance.

Other receivables relate to GST receivables.

### NOTE 5 – PROMISSORY NOTE – PRIME NUMBER ACQUISITION I CORP.

On May 17, 2023, Prime Number Acquisition I Corp. (“PNAC”) issued an unsecured promissory note of \$208,594 (the “noco-noco Note 1”) to evidence the payments made by the Company for the First Monthly Extension payment and 50% of the registration fee for filing of a registration statement/proxy statement in Form F-4 with the U.S. securities and exchange commission. The noco-noco Note 1 bears no interest and is payable in full upon the earlier to occur of (i) the consummation of an initial business combination or (ii) the date of expiry of the term of PNAC, in cash or shares of PNAC at \$10.00 per share, at the discretion of the note holder.

On June 14, 2023, PNAC issued an unsecured promissory note of \$125,000 (the “noco-noco Note 2”) to evidence the payments made by the Company for the Second Monthly Extension payment. The noco-noco Note 2 bears no interest and is payable in full upon the earlier to occur of (i) the consummation of an initial business combination or (ii) the date of expiry of the term of the PNAC, in cash or shares of PNAC at \$10.00 per share, at the discretion of the note holder.

As of June 30, 2023, a total amount of \$333,594 was outstanding under the noco-noco Note 1 and Note 2.

Following the completion of the Business Combination, the promissory note has become an intra-group item to be eliminated, and the Company has no intention of demanding repayment as of the date of issuance of the audited consolidated financial statements

### NOTE 6 – PROPERTY AND EQUIPMENT, NET

Property and equipment consist of the following:

	Office Equipment	Total
<b>Cost</b>		
At July 1, 2021	\$ 15,453	15,453
Additions	3,888	3,888
Effects of movements in exchange rates	(210)	(210)
At June 30, 2022	<u>19,131</u>	<u>19,131</u>
Additions	8,888	8,888
Disposal	(703)	(703)
Effects of movements in exchange rates	948	948
At June 30, 2023	<u>28,264</u>	<u>28,264</u>
<b>Accumulated depreciation</b>		
At July 1, 2021	\$ 5,209	5,209
Depreciation for the year	3,447	3,447
Effects of movements in exchange rates	(132)	(132)
At June 30, 2022	<u>8,524</u>	<u>8,524</u>
Depreciation for the year	4,855	4,855
Disposal	(442)	(442)



Effects of movements in exchange rates	336	336
At June 30, 2023	<u>13,273</u>	<u>13,273</u>

**Carrying amounts**

At July 1, 2021	\$ 10,244	\$ 10,244
-----------------	-----------	-----------

## [Table of Contents](#)

At June 30, 2022	\$	10,607	\$	10,607
At June 30, 2023	\$	14,991	\$	14,991

Depreciation expense for the year ended June 30, 2023 and 2022 was \$4,855 and \$3,447, respectively.

During the year ended June 30, 2023, the Company purchased assets of \$8,888 (\$12,399) and disposed of assets of \$703 (\$952). During the year ended June 30, 2022, the Company purchased assets of \$3,888 (\$5,345).

### NOTE 7 – LEASES

As of June 30, 2023 and 2022, the Company has operating lease agreement for its office premises. Leases with an initial term of 12 months or less are not recorded on the balance sheet. The Company accounts for the lease and non-lease components of its leases as a single lease component. Lease expense is recognized on a straight-line basis over the lease term.

Operating lease right-of-use (“ROU”) assets and liabilities are recognized at commencement date based on the present value of lease payments over the lease term. ROU assets represent our right to use an underlying asset for the lease term and lease liabilities represent our obligation to make lease payments arising from the lease. Generally, the implicit rate of interest (“discount rate”) in arrangements is not readily determinable and the Company utilizes its incremental borrowing rate in determining the present value of lease payments. The Company’s incremental borrowing rate is a hypothetical rate based on its understanding of what its credit rating would be. The operating lease ROU asset includes any lease payments made and excludes lease incentives.

#### *Operating lease*

The Company has entered into commercial operating leases for the use of office premises in Singapore. The lease has varying terms, escalation clauses and run for a period of three years with an option to renew the lease after that term.

When measuring lease liabilities for leases that were classified as operating leases as of June 30, 2023 and 2022, the Company discounted lease payments using its estimated borrowing rate of 5.25%.

Information pertaining to lease amounts recognized in financial statements is summarized as follows:

	June 30, 2023	June 30, 2022
<b>Assets:</b>		
ROU asset	\$ 220,261	\$ 44,925
<b>Liabilities:</b>		
<b>Current:</b>		
Operating lease liabilities	\$ 173,045	\$ 36,385
<b>Non-current</b>		
Operating lease liabilities	36,700	—
<b>Total lease liabilities</b>	<b>\$ 209,745</b>	<b>\$ 36,385</b>

Minimum lease payments for the Company’s operating lease liabilities were as follows for the twelve-month period ended June 30:

	Operating leases
2023	\$ 173,045
2024	36,700
2025	—
Total operating lease payment	<u>\$ 209,745</u>

## [Table of Contents](#)

### NOTE 8 – IMMEDIATE HOLDING COMPANY BALANCES

The Company follows ASC 850, “Related Party Disclosures,” for the identification of related parties and disclosure of related party transactions.

Related parties are any entities or individuals that, through employment, ownership or other means, possess the ability to direct or cause the direction of the management and policies of the Company.

#### Directors’ remuneration

The Directors’ remuneration for the financial years ended June 30, 2023 and 2022 as follow:

	<u>June 30, 2023</u>	<u>June 30, 2022</u>
Andrew Khine	\$ —	\$ 68,242
Shusuke Oguro	—	76,222
Hiroshi Ilzuka	—	41,857
Teo Lai Wah, Timothy	33,002	27,580
Goh Chao Kuang	49,693	—
Hilda Sin Mei Fong	58,125	—
Total	<u>\$ 140,820</u>	<u>\$ 213,901</u>

#### Amounts due to immediate holding company

As of June 30, 2023 and 2022, the Company reported amounts due to immediate holding company, 3DOM Alliance Inc. of amount \$3,572,358 and \$974,632, respectively. These amounts have been reclassified and retrospectively applied to non-current liabilities as the liabilities is expected to be settled over a longer-term horizon from the nature of the promissory note.

The transactions amount due to an immediate holding company are as of the following:

	<u>June 30, 2023</u>	<u>June 30, 2022</u>
Beginning of the year July 1	\$ 974,632	\$ 1,531,488
Advances for operation and administration expenses	2,079,901	873,066
Expenses paid on behalf of Company	1,308,112	117,882
Ordinary shares issued for conversion of debt	(790,287)	(1,547,804)
Year ended June 30	<u>\$ 3,572,358</u>	<u>\$ 974,632</u>

On July 15, 2022, the Company agreed with 3DOM Alliance Inc. to convert the debt amounting to \$790,287 (S\$1,100,000) into ordinary shares of the Company at \$1,041 per share. The Company issued 759 shares of ordinary shares on July 18, 2022.

On January 23, 2023, 3DOM Alliance Inc. issued an amendment of the Original Promissory Note (“First Amendment to Original Promissory Note”) extending the principal amount up to S\$3,000,000 to the Company. There is no other change in terms and conditions to the Original Promissory Note.

On February 2, 2023, the Company requested an additional drawdown of S\$2,980,000 of which 3DOM Alliance Inc. split the amount into two tranches. The Company received S\$1,370,000 on February 3, 2023 and S\$1,610,000 on February 6, 2023.

On February 6, 2023, 3DOM Alliance Inc. further issued an amendment of the Original Promissory Note (“Second Amendment to Original Promissory Note”) extending the principal amount up to S\$8,000,000 to the Company. There is no other change in terms and conditions to the Original Promissory Note. The promissory is interest free and 3DOM Alliance Inc will not demand any payment for at least the next twelve months from the issuance of the financial statements (refer to Note 2).

## **NOTE 9 – SHAREHOLDERS’ EQUITY**

The Company was incorporated on December 28, 2022 with having authorized 500,000,000 ordinary shares with par value of \$0.0001 each. Pursuant to the Business Combination Agreement, upon the consummation of the Share Exchange, New SubCo acquired all the outstanding shares of noco-noco from the Sellers, in exchange, the Seller received such number of newly issued PubCo Ordinary Share that amounted to 126,799,854.

On July 18, 2022, the Company issued 295,824 shares of ordinary shares to 3DOM Alliance Inc. in connection with the conversion of debt (refer to Note 7).

On January 19, 2023, the Company granted 5,071,886 shares to Gregory Hannan and Arun Ramachandran (“Gregory and Arun”) during the incorporation of noco-noco Australia Pty Ltd (“noco-noco Australia) and recognized the stock-based compensation expenses as a settlement of their management expertise in the generation of carbon credits. The Company entered into a Share Swap Agreement (“Share Swap”) on July 19, 2022 with Hop2it Holdings Pte. Ltd. (“Hop2it”) and its two shareholders, Gregory and Arun for the purpose of establishing a carbon abatement management business under Hop2it. In this Share Swap, Gregory and Arun transferred 42% and 10% of their respective Hop2it shares in exchange for 3.2% and 0.8% shares in the Company. This resulted the Company to own 52% interest in Hop2it while the Gregory and Arun own 38% and 10% respectively. Subsequent to the Share Swap, on December 27, 2022, the Company together with Hop2it, Gregory and Arun entered into a Restructuring Deed as all parties have decided to carry out the carbon abatement management business through a newly incorporated entity, noco-noco Australia, instead of Hop2it. This was done by the Restructuring Deed specifying that all future potential economic benefits of the carbon abatement management business of Hop2it (represented by the gross proceeds of potential future sales of carbon credits by Hop2it from anticipated issuance of such credits by regulators in Australia and Papua New Guinea; and the expertise and network of potential clients) are to be assigned to noco-noco Australia. The fair value of the ordinary shares was determined by obtaining quoted prices over-the-counter market based on the latest transacted price of the Company shares that were sold.

The consolidated financial statements for the years ended and as of June 30, 2023 and 2022 were prepared on a retroactive basis to reflect the Group’s consummation of the business combination. The number of shares and net loss per share information is presented as if the consummation took place at the beginning of the period presented.

As of June 30, 2023 and 2022, the Company had 126,799,854 shares and 121,432,144 shares of ordinary shares issued, respectively.

[Table of Contents](#)

**NOTE 10 – INCOME TAX**

noco-noco Pte. Ltd. is incorporated in Singapore, and under the current tax laws of Singapore, its standard corporate income tax rate is 17%.

Due to the Company's net loss position, there was no provision for income taxes recorded. Management considers positive and negative evidence to determine whether some portion or all of the deferred tax assets will more-likely-than-not be realized. This assessment considers, among other matters, the nature, frequency and severity of recent losses, forecasts of future profitability, and the duration of statutory carry forward periods. Valuation allowances have been established for deferred tax assets based on a more-likely-than-not threshold. Due to a history of losses, the Company assessed it was not more likely than not that the deferred tax assets would be realized in the foreseeable future.

	June 30, 2023	June 30, 2022
<b>Loss before tax</b>	\$ 16,791,770	\$ 1,076,823
Tax rate	17%	17%
Computed tax benefit (expense) at statutory tax rate	2,854,601	183,060
<b>Tax effect of non-deductible or taxable items:</b>		
Share-based compensation expenses	(2,236,523)	-
Additional deduction for R&D expenses	—	11,680
Change in valuation allowance	(618,078)	(194,740)
Effect of preferential tax rates	—	—
<b>Income tax expense (benefit)</b>	<u>—</u>	<u>—</u>

The Company evaluates each uncertain tax position (including the potential application of interest and penalties) based on the technical merits, and measure the unrecognized benefits associated with the tax positions. As of June 30, 2023 and 2022, the Company did not have any significant unrecognized uncertain tax positions. The Company did not accrue any liability, interest or penalties related to uncertain tax positions in its provision for income taxes line of its consolidated statements of operations for the years ended June 30, 2023 and 2022. The Company does not believe that its uncertain tax benefits position will materially change over the next twelve months.

As of June 30, 2023, Singapore tax returns for the years 2020 to 2023 are subject to examination by the tax authorities.

Deferred taxes were measured using the enacted tax rates for the periods in which the temporary differences are expected to be reversed. The tax effects of temporary differences that give rise to the deferred tax balances as of June 30, 2023 and 2022 are as follows:

	June 30, 2023	June 30, 2022
<b>Deferred tax assets</b>		
Net operating loss carry-forward	\$ 1,015,370	\$ 391,242
Capital allowance	4,805	3,253
Lease liabilities	35,657	6,185
Other provisions	22,470	22,471
Less: valuation allowance	(1,040,858)	(415,300)
Subtotal	<u>37,444</u>	<u>7,851</u>
<b>Deferred tax liabilities</b>		
Deferred tax liabilities arising from assets	<u>(37,444)</u>	<u>(7,851)</u>
Total deferred tax assets, net	<u>—</u>	<u>—</u>

The Company had net operating loss carried forward for tax purposes of approximately \$5,972,000 as of June 30, 2023 and approximately \$2,351,000 as of June 30, 2022, which may be carried forward indefinitely to offset future taxable income.

	June 30, 2023	June 30, 2022
<b>The changes related to valuation allowance are as follows:</b>		
Balance at the beginning of the year	\$ 415,300	\$ 220,560
Current year addition	<u>625,558</u>	<u>194,740</u>

Balance at the end of the year

1,040,858

415,300

## [Table of Contents](#)

### **NOTE 11 – COMMITMENTS AND CONTINGENCIES**

In the normal course of business, we are subject to loss contingencies, such as legal proceedings and claims arising out of our business, that cover a wide range of matters, including, among others, government investigations and tax matters. In accordance with ASC No. 450-20, “Loss Contingencies”, we will record accruals for such loss contingencies when it is probable that a liability has been incurred and the amount of loss can be reasonably estimated. In the opinion of management, there were no pending or threatened claims and litigation as of June 30, 2023 and through November 14, 2023, the date the financial statements were available to be issued.

### **NOTE 12 – SUBSEQUENT EVENTS**

In accordance with FASB ASC 855-10 Subsequent Events, the Company has analyzed its operations subsequent to June 30, 2023 to the date these consolidated financial statements were issued, and has determined that there is a material subsequent event to disclose in these consolidated financial statements, because we believe that this event will have a significant effect on the future operations of the Company.

On July 14, 2023, PNAC issued an unsecured promissory note of \$125,000 (the “noco-noco Note 3”) to evidence the payments made by the Company for the Third Monthly Extension payment. The noco-noco Note 3 bears no interest and is payable in full upon the earlier to occur of (i) the consummation of an initial business combination or (ii) the date of expiry of the term of the PNAC, in cash or shares of PNAC at \$10.00 per share, at the discretion of the note holder.

On August 13, 2023, the Company entered into a Forward Purchase Agreement (the “Forward Purchase Agreement”) and Subscription Agreement (the “FPA Subscription Agreement”) with (i) Meteora Capital Partners, LP (“MCP”), (ii) Meteora Select Trading Opportunities Master, LP (“MSTO”), and (iii) Meteora Strategic Capital, LLC (“MSC” and, collectively with MCP and MSTO, the “Meteora Parties”) for an OTC Equity Prepaid Forward Transaction. Pursuant to the terms of the Forward Purchase Agreement and FPA Subscription Agreement, Seller agreed to subscribe for and purchase, and the Company agreed to issue and sell to Seller, on the Closing, up to 2,000,000 Class A Common Stock of the Company, less the number of Class A Common Stock of the Company purchased by Seller separately from third parties through a broker in the open market at prices no higher than the redemption price. Seller has agreed to waive any redemption rights under the Company’s current Charter with respect to any Class A ordinary shares of the Company purchased through the FPA Subscription Agreement and any Recycled Shares (as defined Form F1 File No. 001-41789) in connection with the Business Combination, extensions or otherwise that would require redemption by the Company of such shares.

On August 14, 2023, PubCo entered into a purchase agreement (the “ELOC Purchase Agreement”) with ARENA BUSINESS SOLUTIONS GLOBAL SPC II, LTD on behalf of and for the account of SEGREGATED PORTFOLIO #9 – SPC #9 (“Arena”), which provides that, upon the terms and subject to the conditions and limitations set forth therein, PubCo has the right to direct Arena to purchase up to an aggregate of \$150,000,000 of PubCo Ordinary Shares over the 36-month term of the ELOC Purchase Agreement. Under the ELOC Purchase Agreement, after the satisfaction of certain commencement conditions, including, without limitation, the effectiveness of the Resale Registration Statement (as defined below), PubCo has the right to present Arena with an advance notice (each, an “Advance Notice”) directing Arena to purchase any amount of PubCo Shares (each, an “Advance”) up to the Maximum Advance Amount (as defined herein). After the SEC declares a Resale effective relating to the transaction, PubCo will have the right and the sole discretion to sell to Arena up to \$150 million worth of shares over a 36-month period subject to certain limitations. PubCo will control the timing and amount of any future investment and Arena will be obligated to make purchases in accordance with the ELOC Purchase Agreement

On August 17, 2023, PNAC issued an unsecured promissory note of \$125,000 (the “noco-noco Note 4”) to evidence the payments made by the Company for the Forth Monthly Extension payment. The noco-noco Note 4 bears no interest and is payable in full upon the earlier to occur of (i) the consummation of an initial business combination or (ii) the date of expiry of the term of the PNAC, in cash or shares of PNAC at \$10.00 per share, at the discretion of the note holder.

On August 25, 2023 (the “Closing Date”), noco-noco Inc. (formerly known as Prime Number Holding Limited), an exempted company with limited liability incorporated under the laws of the Cayman Islands (the “Company” or “PubCo”), consummated the previously announced Business Combination (defined below). The Business Combination was announced on December 29, 2022, where PubCo, Prime Number Acquisition I Corp. (“PNAC”), Prime Number Merger Sub Inc., a Delaware corporation and a direct wholly-owned subsidiary of PubCo (“Merger Sub”), Prime Number New Sub Pte. Ltd., a Singapore private company limited by shares and a direct wholly-owned subsidiary of PubCo (“New SubCo”), noco-noco Pte. Ltd., a Singapore private company limited by shares (“noco-noco”), and certain shareholders of noco-noco collectively holding a controlling interest (together with other shareholders of noco-noco subsequently joining the transactions, the “Sellers”), entered into a business combination agreement (“Business Combination Agreement”), pursuant to which, PNAC proposed to enter into a business combination with noco-noco involving a merger and a share exchange, among which: (i) Merger Sub would merge with and into PNAC, with PNAC as the surviving entity and a wholly-owned subsidiary of PubCo (the “Merger”), (ii) New SubCo would acquire all of the issued and

outstanding shares of noco-noco from the Sellers, and in exchange, PubCo would issue to the Sellers the ordinary shares of PubCo, with noco-noco becoming a subsidiary of New SubCo and an indirect subsidiary of PubCo (the “Share Exchange”, and together with the Merger and the other transactions contemplated by the Business Combination Agreement, the “Business Combination”). Upon the



## [Table of Contents](#)

consummation of the Business Combination, each of PNAC and noco-noco would become a subsidiary of PubCo, and PNAC stockholders and the Sellers would receive ordinary shares, par value \$0.0001 per share, of PubCo (“PubCo Ordinary Shares”) as consideration and become the shareholders of PubCo. The Merger was consummated on August 24, 2023, and the Share Exchange and Business Combination were consummated on the Closing Date.

Pursuant to the Business Combination Agreement, upon the consummation of the Business Combination: (i) each PNAC unit (“PNAC Units”) issued and outstanding immediately prior to the effective time of the Merger was automatically detached and the holder thereof was deemed to hold one share of PNAC Class A Common Stock (defined below), one half of PNAC Warrant (defined below), and one PNAC Right (defined below); (ii) each share of PNAC Class A common stock, par value \$0.0001 per share (“PNAC Class A Common Stock”, together with PNAC Class B Common Stock, par value \$0.0001 per share, the “PNAC Common Stock”) issued and outstanding immediately prior to the effective time of the Merger was canceled in exchange for the right to receive one PubCo Ordinary Share, (iii) each PNAC warrant (“PNAC Warrant”) outstanding immediately prior to the effective time of the Merger ceased to be a warrant with respect to PNAC Common Stock and was assumed by PubCo and converted into a warrant of PubCo (“PubCo Warrant”) to purchase one PubCo Ordinary Share subject to substantially the same terms and conditions prior to the effective time of the Merger; and (iv) each PNAC Right (“PNAC Right”) outstanding immediately prior to the effective time of the Merger was cancelled in exchange for the right to receive one-eighth (1/8) of one PubCo Ordinary Share. In addition, pursuant to the Business Combination Agreement, upon the consummation of the Share Exchange (i) New SubCo acquired all the outstanding shares of noco-noco (“noco-noco Shares”) from the Sellers, (ii) in exchange, each Seller received such number of newly issued PubCo Ordinary Share that was equal to the product of (a) the quotient of (i) \$1,350,000,000 (the “noco-noco Valuation”), divided by (ii) the price per PubCo Ordinary Share that equals to the redemption price of each share of PNAC Class A Common Stock in connection with the Business Combination (the “PubCo Per Share Price”), multiplied by (b) such Seller’s Pro Rata Portion as set out in the Allocation Schedule of the Business Combination Agreement.

On August 28, 2023, the PubCo Ordinary Shares and PubCo Warrants commenced trading on the Nasdaq Capital Market (“Nasdaq”) under the symbols “NCNC” and “NCNCW”, respectively.

On October 23, 2023, noco-noco Inc., through its Singapore subsidiary, noco-noco Pte. Ltd. has entered into a Sales and Purchase Agreement to acquire noco-tech Inc. (“noco-tech”), a technology innovator from 3DOM Alliance Inc. (“3DOM”). The agreement includes an indefinite license to produce and market the X-SEPA™ separator technology developed by 3DOM. Under the terms of the transaction, noco-noco will issue up to twenty-five million new shares at US\$2 per share to fund the acquisition. The transaction is expected to close in Q4 of 2023. Completion of the Sale and Purchase Agreement is subject to customary conditions precedent, which includes satisfactory completion of due diligence, and noco-noco having obtained the approval of its shareholders for the transaction and necessary regulatory consents and approval (as applicable) for the transaction.